

UNCLASSIFIED

ACP 125 (F)

ALLIED COMMUNICATIONS PUBLICATION

COMMUNICATION INSTRUCTIONS

RADIOTELEPHONE PROCEDURES

ACP 125(F)



September 2001

Released 5 September 2001
(Reverse Blank)

UNCLASSIFIED

THIS PAGE INTENTIONALLY BLANK

Released 5 September 2001

UNCLASSIFIED

II

FOREWORD

1. ACP 125(F), COMMUNICATION INSTRUCTIONS RADIOTELEPHONE PROCEDURE, is an UNCLASSIFIED publication. Periodic accounting is not required.
2. ACP 125 (F) will be effective for national, service, or Allied use when directed by the appropriate implementing agency.
3. When made effective, ACP 125(F) supersedes ACP 125(E), which will be disposed of in accordance with current organizational regulations.
4. This publication contains Allied military information and is furnished for official purposes only.
5. It is permitted to copy or make extracts from this publication.

THIS PAGE INTENTIONALLY BLANK

Released 5 September 2001

UNCLASSIFIED
IV

**THE COMBINED COMMUNICATION-ELECTRONICS BOARD
LETTER OF PROMULGATION
FOR ACP 125(F)**

1. The purpose of this Combined Communication Electronics Board (CCEB) Letter of Promulgation is to implement ACP 125 within the Armed Forces of the CCEB Nations. ACP 125(F), Communication Instructions Radiotelephone Procedure, is an UNCLASSIFIED publication developed for Allied use and, under the direction of the CCEB Principals. It is promulgated for guidance, information, and use by the Armed Forces and other users of military communications facilities.

2. ACP 125(F) will be made EFFECTIVE WHEN DIRECTED by the CCEB and, when effective, will supersede ACP 125(E), which shall be destroyed in accordance with National regulations. The effective status of this publication is shown below.

EFFECTIVE STATUS

Publication	Effective for	Date	Authority
ACP125F	CCEB	When Directed	LOP

3. Service-originated correspondence will be forwarded through the normal military chain of command, marked for the attention of the appropriate Service communications chief or director. All proposed amendments to the publication are to be forwarded to the national coordinating authorities of the CCEB.

For the CCEB Principals

R. McTeague
Wing Commander
Chairman of the CCEB Washington Staff

Released 5 September 2001
(Reverse Blank)

THIS PAGE INTENTIONALLY BLANK

Released 5 September 2001

UNCLASSIFIED
VI

NET DIAGRAMS

The following net diagrams illustrate the net organisation used in the examples in this publication. The call signs are of types derived from ACP 135 and are used solely to standardise examples.

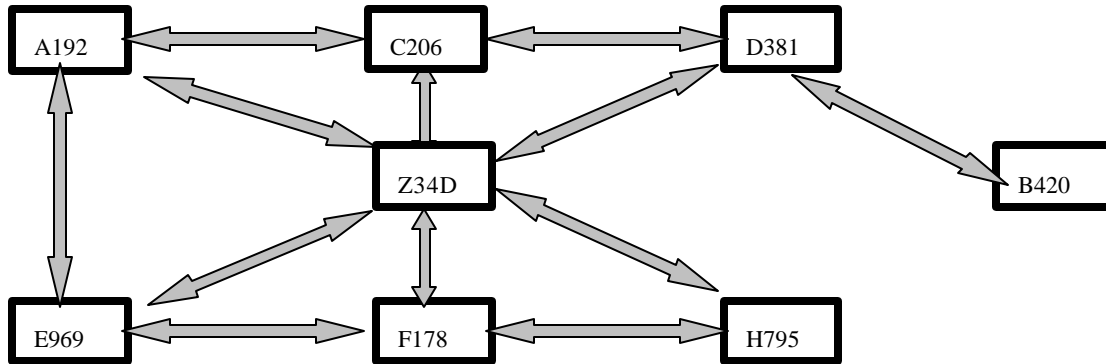

Net Control Station is Z34D
Net Call Sign is Y13C
Off-Net station used in examples is B420

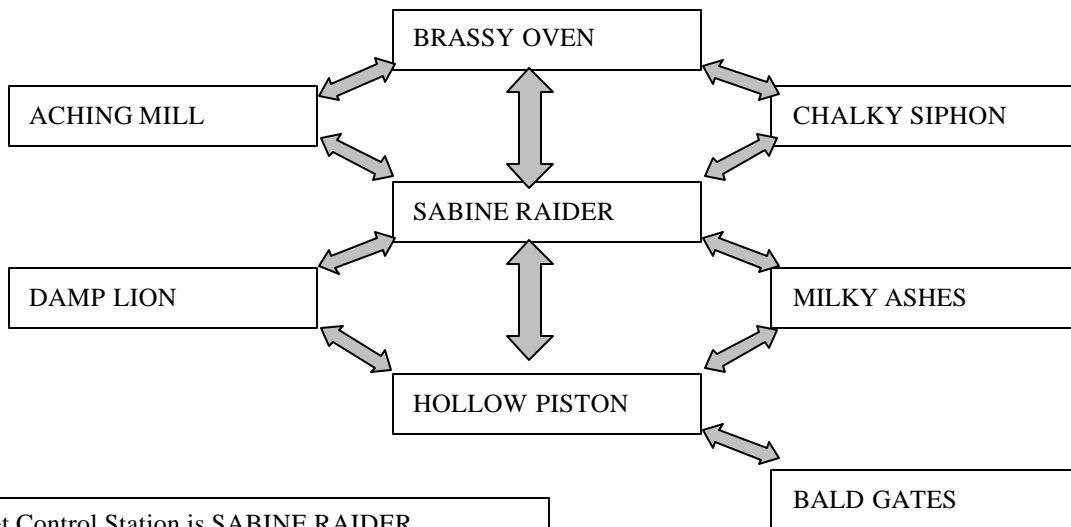

Net Control Station is SABINE RAIDER
Net Call Sign is RESORT PRIZE
Off-net station used in examples is BALD GATES

THIS PAGE INTENTIONALLY BLANK

Released 5 September 2001

UNCLASSIFIED
VIII

RECORD OF MESSAGE CORRECTIONS

Enter Change or Correction in Appropriate Column

Message Correction Number	JAFPUB Number	Date Time Group	By Whom Entered

THIS PAGE INTENTIONALLY BLANK

Released 5 September 2001

UNCLASSIFIED

X

THIS PAGE INTENTIONALLY BLANK

Released 5 September 2001

UNCLASSIFIED
XII

Table of Contents

Title Page.....I
Foreword.....III
Letter of Promulgation.....V
Net Diagram.....VII
Record of Message CorrectionsIX
Record of Pages Checked.....XI
Table of Contents.....XIII

Chapter 1

General

101. General1-1
102. Voice Procedure1-2
103. Protocols1-2
104. Callsigns1-2
105. Secure Nets1-2
106. Codes1-2
107. Encryption of Plain Text.....1-3

Chapter 2

Security

201. The Radio War2-1
202. Intercepted Information2-1
203. Security of Information2-2
204. Communications Security2-3
205. Transmission Security2-3
206. Defence Against Interception2-4
207. Defence Against Analysis2-5
208. Defence Against Deception2-6
209. Aid to Security2-7
210. Low Level Codes2-8
211. What to Encode2-8
212. Real or Non-Exercise Traffic2-9
213. Authentication2-9
214. Authentication Systems2-9
215. Codewords2-9
216. Radio Appointment Titles2-9
217. Address Groups2-10

Released 5 September 2001

218. Callsigns2-10

Chapter 3

Accuracy

301. General3-1
302. Speech Technique3-1
303. Aids to Accuracy3-2
304. Rules for Spelling3-3
305. Encrypted Text3-4
306. Rules for Figures3-4
307. Rules for Mixed Groups3-5
308. Aids to Brevity3-6
309. Legibility of Characters3-9

Annex A to Chapter 3

List of Prowords and their Equivalent Prosigns or Operating signals.....3-12

Chapter 4

Discipline

401. General.....4-1
402. Rules for Radio Discipline4-1
403. Radio Logging4-2

Chapter 5

Messages

501. Plaindress5-1
502. Abbreviated Plaindress5-1
503. Codress5-1
504. Service Message5-2
505. Abbreviated Service Message5-2
506. Informal Messages5-2
507. Classification of Service and Abbreviated Serviced Messages5-3
508. Long Message Procedure5-3
509. Message Format5-4

Released 5 September 2001

UNCLASSIFIED

UNCLASSIFIED

ACP 125 (F)

510. Schematic Diagram of Message Format5-4
511. Format Lines 2 and 3 (Calling and Answering)5-6
512. Format Line 4 (Transmission Instructions)5-9
513. Format Line 5 (Preamble)5-9
514. Format Lines 6, 7, 8 and 9 (Address)5-9
515. Format Line 10 (Prefix)5-12
516. Format Line 11 (Separation)5-12
517. Format Line 12 (Text)5-13
518. Format Line 13 (Separation)5-13
519. Format Line 14 (Time Group)5-13
520. Format Line 15 (Final Instructions)5-13
521. Format Line 16 (Ending Sign)5-13

Chapter 6

Operating Rules

601. General.....6-1
602. Authentication6-2
603. Establishing Communications6-2
604. Sequence of Call Signs and/or Address Groups6-3
605. Establishing Net6-3
606. Establishing Communications6-5
607. Establishing a Net (Tuning)6-7
608. Directing a Shift in Frequency6-8
609. Directed and Free Nets6-10
610. Delegating and Assuming Net Control6-12
611. Radio Checks, Signal Strength and Readability6-14
612. Preliminary Calls6-16
613. Transmitting a Message6-17
614. Relay6-19
615. Repetitions6-22
616. Checking the Group Count6-26
617. Corrections6-28
618. Cancelling Messages6-31
619. Do Not Answer Transmissions6-31
620. Read Back6-32
621. Receipt6-34
622. Acknowledgement of Messages6-37
623. Verifications6-37
624. Break-in Procedure6-39
625. Electronic, Radio and Emergency Silence6-41
626. Closing Down6-45

Released 5 September 2001

Chapter 7

Executive Method

701. Purpose.....	7-1
702. Executive methods.....	7-1
703. Delayed Executive Method.....	7-3
704. Immediate Executive Method.....	7-4
705. Acknowledgement of Signals.....	7-5
706. Verification and Repetitions.....	7-6
707. Execution of Non-Executive Method Messages.....	7-8
708. Cancelling Tactical Messages.....	7-9

Chapter 8

Miscellaneous Procedures

801. Method of Synchronizing Time.....	8-1
802. Grid References.....	8-2
803. Beadwindow Procedure.....	8-2

Chapter 9

Procedures for Reporting Enemy Contacts

901. Introduction	9-1
902. Transmission of Enemy Reports	9-1
903. Examples of Enemy Contact Reports	9-2
List of Effective Pages	LEP-1

Released 5 September 2001

UNCLASSIFIED

XVI

CHAPTER 1

GENERAL

101. GENERAL

The aim of ACP125 is to prescribe the voice procedure for use by the armed forces of Allied nations on secure and insecure tactical voice nets. Its purpose is to provide a standardized way of passing speech and data traffic as securely as possible consistent with accuracy, speed and the needs of command and control.

- a. Voice procedure is necessary because:
 - (1) Speech on a congested voice net in battle must be clear, concise and unambiguous. To avoid interference between speech and data, it will often be expedient to assign the passage of data traffic to logistic or admin nets rather than to those directly associated with command and control.
 - (2) It must be assumed that all transmissions will be intercepted and analysed by potential adversaries, and used to provide radio location and signals intelligence. The use of a standard procedure is an important security measure against the constant threat of enemy electronic warfare activities.
 - (3) Some form of discipline is needed to ensure that transmissions do not overlap, if two people send at one time the result is chaos.
- b. Adherence to the procedure prescribed in ACP125 is mandatory on all Allied military tactical secure and insecure voice nets. Departure from, or variations in these procedures is prohibited. Such action can invalidate security precautions, reduce accuracy and speed, and create confusion. If the procedure does not cater for a specific situation, common sense and training experience should be used as a guide. Standard procedure must never be substituted with individually preferred methods, or the latter used as an excuse for lack of procedural expertise.
- c. The rules for Voice Procedure are frequently reviewed and changed as necessary. Suggestions for change are welcome and should be forwarded

to the appropriate Signal School for coordination and despatch to the national defence procedures authority.

102. VOICE PROCEDURE

The term Voice Procedure encompasses three related elements:

- a. Protocol. The rules of use – how to start and finish a message. On mixed voice and data nets this includes the prowords used for the passage of data traffic.
- b. Callsigns. Figures, letters, or combinations of both used to identify a communications station, an organization, or an individual on a radio net.
- c. Secure Nets and Codes. The cryptographic systems employed to protect secure nets, and the codes used to provide some degree of cryptographic protection for information transmitted over insecure nets.

103. PROTOCOLS

The protocols in this publication are designed to reduce wherever possible, consistent with accuracy, the time spent in the transmission of voice communications drills, message text and data traffic.

104. CALLSIGNS

The voice callsign system seeks to conceal from an enemy who is talking to whom, hence the level of command, composition and purpose of the net. Callsign systems are devised to make all nets sound the same to an intercepting operator or analyst. Unless considerable time is spent in monitoring and searching for telltale traffic, the nature, composition and purpose of an insecure net should not be obvious.

105. SECURE NETS

Traffic passed over a secure net must not be classified higher than the classification assigned to the crypto net variable in use. The rules for voice procedure apply equally to secure and insecure nets.

106. CODES

Tactical codes are designed to provide:

- a. Concealment of exploitable text.

Released 5 September 2001

UNCLASSIFIED

- b. Authentication tables.

107. ENCRYPTION OF PLAIN TEXT

The variety of operations in which Allied forces may be involved, the ability or otherwise of hostile agencies to respond to information passed over insecure nets and the threats to communications in peacetime, require commanders and communicators at all levels to exercise judgement as to what should and should not be enciphered. Decisions arrived at should be based on the guidelines given in this publication.

THIS PAGE INTENTIONALLY BLANK

Released 5 September 2001

UNCLASSIFIED

1-4

CHAPTER 2

SECURITY

201. THE RADIO WAR

The range, efficiency and traffic capacity of modern radios provide an excellent method of communication. Unfortunately, unencyphered radio is the least secure of all means of communications. The unauthorised interception and recording of radio transmissions is impossible to detect or prevent.

- a. Military radio communications are a constant source of valuable intelligence to potential adversaries, both in peace and war. Information collected in peacetime is available for long term analysis by a potential enemy and is extremely useful for the planning of operations against Allied forces in time of war. This task is simplified by the often unwitting relaxation of security precautions during training exercises, actions that would be considered unthinkable in war. Inferior security and operating procedures practised in peacetime are unlikely to be discarded/corrected immediately prior to operations in time of crisis.
- b. Enemy response to security breaches made in wartime can be expected to be immediate. Even secure radio communications can provide considerable intelligence from characteristic patterns, traffic flow and the location of transmitters obtainable by direction finding (DF).
- c. It must be assumed that every radio transmission made during training exercises or on operations will be intercepted and evaluated by hostile signal intelligence (SIGINT) agencies, and the resulting intelligence ultimately used against Allied nations.

202. INTERCEPTED INFORMATION

This constant monitoring of Allied radio communications and the study and interpretation of the various traffic characteristics provide the enemy with vital current information concerning fighting capabilities.

- a. Intercepted information, when analysed and correlated with existing data from other sources, can provide intelligence of sufficient value to influence significantly enemy command decisions.

Released 5 September 2001

b. Whether from direct security breaches or the provision of indirect clues through the indiscreet use of plain language, a potential enemy will attempt to discover:

(1) Task Organisation or Order of Battle

Command structure.
Radio net level, composition and function.
Ship and unit identities.

(2) Locations

Formation and unit boundaries.
Areas of operation.
Location of command ships and headquarters.

(3) Intentions

Operations plans.
Tactical groupings.
Movement.

(4) Combat Effectiveness

Casualties.
Damaged or defective ships, vehicles and equipment.
Standard of radio discipline.

203. SECURITY OF INFORMATION

a. Whether transmitted during training or on operations, all information of a long or short term nature likely to assist an enemy in wartime should be encoded, whenever possible, prior to its transmission on insecure radio. It is mandatory to encode:

(1) Positions, bearings and distances, stations, datum and reference points, grid references or place and ships names identifying location of friendly forces.

(2) Positions, bearings and distances, datum and reference points, grid references or place and ship's names identifying locations of enemy forces if the information is gained by stealth. When both

Released 5 September 2001

UNCLASSIFIED

friendly and enemy forces are aware that contact has been made, in other words after an exchange of fire has taken place, contact reports may be sent in the clear.

- (3) Start lines.
 - (4) FUPs and routes.
 - (5) Harbours and Tides.
 - (6) Timings.
 - (7) Future intentions (including "Warning Orders", "Orders" and "No Move Before" etc).
- b. Once sensitive information has been transmitted in the clear, there is no guaranteed period of safety and it must be assumed that enemy reaction will be immediate.
 - c. Each transmission must be carefully considered and the risk calculated. The rival priorities of security and speed are to be carefully weighed and balanced against the enemy's ability to intercept and exploit the transmitted information.

204. COMMUNICATIONS SECURITY

Communications Security (COMSEC) is the collective title for the measures taken to protect all aspects of communications in order to deny information and intelligence to an enemy. This includes cryptographic security details of which are contained in national cryptographic instructions.

205. TRANSMISSION SECURITY

Transmission Security is that component of COMSEC which includes all measures designed to protect Allied radio transmissions from enemy interception, analysis and deception.

- a. Interception. Interception is the act of searching for, listening to and recording radio communications and electronic transmissions for the purpose of obtaining information.

- b. Analysis. Analysis is the examination and interpretation of intercepted radio communications traffic and electronic transmissions for the purpose of obtaining intelligence.
- c. Deception. Deception is the introduction of a false transmission into a communications system, by imitating an authentic transmission, with the intention to deceive or create confusion.

206. DEFENCE AGAINST INTERCEPTION

The use of radio is part of an overall Emission Control (EMCON) policy and is a command function decided at the highest level.

- a. No radio transmission, can be regarded as safe from interception. It is important to remember that intercept receivers are designed to receive weaker signals at greater distances than standard receivers do.
- b. Maximum defence against interception and DF can be achieved if the following protective measures are taken:
 - (1) Radio Silence. Radio silence (defined in ACP167) is the only conclusive defence against interception. Instructions and procedures regarding the imposition, breaking and lifting of radio silence must be rigidly adhered to if the expected protection they can provide against enemy interception is to be attained. The lifting of radio silence does not allow radio to be used indiscriminately.
 - (2) Electronic Silence. Orders for the imposition of electronic silence may be passed over the radio by the use of a codeword issued by the general staff.
 - (3) Avoiding Unnecessary Transmissions. The necessity for each radio transmission should be carefully considered; radio is often used habitually when adequate alternative methods of communication are available. Having decided to make a transmission, called stations should be limited to essential addressees only to avoid unnecessary replies and acknowledgements. The checking of communications and associated transmitter tuning and testing should be reduced to an absolute minimum.

Released 5 September 2001

UNCLASSIFIED

- (4) **Transmission Length.** The longer a transmission the more vulnerable it is to intercept and DF. Individual transmission should not exceed 20 seconds and, whenever possible, terminated with the proword OUT. The pressel should always be released during pauses in procedure. The same principle should be applied to data transmissions.
- (5) **Procedure.** Poor procedure can increase transmission time and cause a series of unnecessary transmissions requesting clarification. Strict adherence to correct message procedure and communication drills, combined with good net discipline, will minimise transmission time and reduce vulnerability to interception and DF. Measures must be taken to avoid the continuous repetition of data messages – the danger is that unless an automatic acknowledgement is received from the intended recipient a data message may be repeated ad infinitum.
- (6) **Changing Frequency.** Changing frequency can break continuity of interception. Whenever possible, on insecure nets, the instruction to change frequency should be encoded or passed by secure means – this is important when the change occurs at an unpredictable time. Frequencies are never to be passed in clear over insecure radio.
- (7) **Use of Alternative Means of Communications.** The maximum use should be made of communications other than radio, particularly where a delayed response is acceptable to the originator.

207. DEFENCE AGAINST ANALYSIS

The following measures should be taken to render enemy traffic analysis more difficult and any resulting intelligence less reliable:

- a. **Calling and answering.** The greater the number of stations included in a call, the more potential intelligence there is available to an analyst to decide the composition, size and level of a net. For this reason, all station calls and large multi-station calls are unduly detrimental to security; their use should be confined to exceptional, unavoidable circumstances. Collective calls have the advantage of brevity without the need to divulge each callsign in the initial call but, used excessively, subsequent answering calls will soon provide the analyst with their grouping and identity.
- b. **Callsign omission.** After initial calling and answering calls have been made and the identities of the calling and called stations have been

Released 5 September 2001

satisfactorily established, callsigns should be omitted entirely unless circumstances demand otherwise. In addition to denying the analyst useful repetition and confirmation of callsigns, overall transmission time is reduced.

- c. **Locations.** Locations, whether Allied or those of an adversary, are the most sensitive information sent over radio and are an unrivalled source of intelligence; an analyst can invariably relate unencoded enemy locations to friendly forces' positions. This is often due to the inadvertent disclosure of associated plain language, in either the same or other messages, combined with the analyst's knowledge of Allied tactical doctrine. Furthermore, an enemy commander, given that he is aware Allied forces know of his positions, can take appropriate counter action. As a general rule, all locations should be encoded.
- d. **Plain Language.** Plain language information of an obviously sensitive nature must be encoded prior to transmission over insecure radio. Every effort should also be made to identify and encode plain language information that may in isolation appear innocuous but when assembled with other similar information by an analyst becomes classified. Ideally, with the sensible use of vocabulary codes, transmissions should contain the minimum of exploitable plain language text.
- e. **Avoiding Compromise.** Plain language reference to callsigns, address groups, tactical codes or other security aids is forbidden and must be constantly guarded against is the security value and protection they offer is not to be compromised. Linkage or compromise enabling continuity between old and new operating frequencies must be avoided.
- f. **Standardisation.** Idiosyncrasies of speech and operating techniques enable the analyst, aided by a comprehensive filing system, to recognize an individual, his ship or unit and its expected role. The aim of every radio user should be to remain anonymous. The names of personnel, ships or units must never be transmitted in clear. Unique personal expressions or mannerisms, jargon and mention of specialist items of equipment must be avoided.

208. DEFENCE AGAINST DECEPTION

An enemy will rarely attempt deception during peacetime, but almost exclusively reserve its use for time of war to ensure maximum impact. Unsuspecting stations preoccupied

Released 5 September 2001

UNCLASSIFIED

with urgent tactical matters are particularly prone to this method of attack. The best defences against enemy deception are:

- a. Good Procedures. The success of enemy deception relies on his ability to appear inconspicuous, which is mainly dependent on his knowledge of Allied operation procedures.
- b. Constant Vigilance. Radio users and operators must remain alert to irregularities in procedure, unfamiliar speech and unexpected transmissions of dubious origin. Subtle use of previously recorded transmissions of Allied nets, played back by an enemy, can cause confusion and endanger Allied troops; these may not necessarily be on the same net or within a similar time frame. Special care must also be taken to identify and ignore counterfeit transmissions made solely to solicit answering calls, normally for DF purposes, when radio silence is in force. Whenever deception is recognised, or suspected, it should be reported immediately by secure means in accordance with national reporting procedures.
- c. Authentication. The correct and timely use of authorised authentication systems help protect Allied nets against enemy communications deception. The requirement for good authentication practices is less apparent in training, but will contribute significantly to combat survival and effectiveness in time of war.

209. AID TO SECURITY

- a. There are procedural aids which can considerably enhance transmission security. The degree and period of security protection afforded by these aids is greatly dependent on their correct use. This requires a thorough understanding of their potential and also their limitations. Abuse or misuse of security aids will quickly counter their security value and, equally dangerously instill a false sense of security.
- b. Unofficial, locally designed codes or adaptation of official codes, however well intentioned, will not deceive a cryptanalyst; only officially authorised codes are to be used. Aids to security are:
 - (1) Authorised low-level codes.
 - (2) Authentication.
 - (3) Codewords.

Released 5 September 2001

- (4) Address groups
- (5) Callsigns.
- (6) Net identification signs.

210. LOW LEVEL CODES

Low level codes are designed to provide security protection for sensitive short-term tactical information where speed and simplicity of operation are the overriding considerations. When time and circumstances permit, secure communications systems or alternative physical methods should be used.

211. WHAT TO ENCODE

- a. Apart from the rules specified in paragraph 203, there can be no hard and fast guidance on what else in a message may be exploitable text in any particular circumstance. Military judgement must be exercised in every case to answer the following questions:
 - (1) How much information am I prepared to let the enemy obtain from my radio traffic?
 - (2) How might the enemy exploit the information I am about to transmit?
- b. Exploitable text is that which provides useful information for an enemy to use in a timely way (his response time can be expected to be as little as a few minutes) to our disadvantage; it includes locations and timings, assembly areas, start lines, ship and unit states and indications of intentions. Such indications include “warning orders”, “orders”, “no move before”, etc. Their exploitability must be judged according to the tactical situation at the time. For example, in the heat of battle, “orders” may be commonplace and of no significance to an enemy; on the other hand, during a lull, a “warning order” may be the key to his discovering the time and place of a counter attack. For added guidance the policy about what may or may not normally be sent by unprotected means will be laid down by the Allied/theatre/command HQ concerned.
- c. All exploitable text must be encoded whenever the situation permits. If the delay imposed by encoding a message, or parts of a message, will

Released 5 September 2001

UNCLASSIFIED

UNCLASSIFIED

ACP 125 (F)

prejudice the operation more than the plain text transmission will
prejudice its security then the message may be sent in plain text at the
discretion of the originator. However, he must understand that he may be
called upon to justify his decision.

Released 5 September 2001

UNCLASSIFIED

2-9

212. REAL OR NON-EXERCISE TRAFFIC

In training, there is a need to differentiate between exercise play and events, which require action outside the context of the exercise; conventionally this is known as "real" activity. Messages associated with real activity are just as exploitable as any other and care must be taken to ensure that security is not unduly prejudiced by the urgency of such situations. In order to highlight the differences between real and other messages, the proword NO PLAY is used. Its meaning is defined in the list of prowords at Annex A to Chapter 3

213. AUTHENTICATION

Authentication is a security aid designed to protect Allied communications against deception from fraudulent transmissions by unauthorised persons.

214. AUTHENTICATION SYSTEMS

The type of authentication system in use will usually depend upon the type of net, ie ship, unit command or formation level. Challenge and reply authentication is common to unit and formation nets, transmission or self-authentication is normally confined to Allied formation or specialised nets. The rules concerning the occasions when authentication should be used, with examples, are contained in Chapter 6.

215. CODEWORDS

A codeword is a single word with a pre-arranged meaning, used to establish a condition, an alert, or to initiate the implementation of a plan or operation. Codewords are prepared and issued by the Operations Staff. Their meanings are always classified and are intended to be used once only as an executive order. They may therefore be sent in clear. Codewords are rarely used in connection with communications, other than for conditions of electronic silence.

216. RADIO APPOINTMENT TITLES

Radio appointment titles are not codewords. They may be authorised for combined, national or joint working as required. With the exception of SUNRAY and SUNRAY MINOR, which may be used for the Commander and second-in-command on Marine, Army and Air Force tactical nets, appointment titles are not normally used.

Released 5 September 2001

UNCLASSIFIED

217. ADDRESS GROUPS

An address group is a unique, daily changing group of four random letters used to disguise a command, formation, unit or sub unit. Address groups are classified when connected with their meaning. The Allied theatre or command HQ will determine the classification of address groups.

- a. Use of Address Groups. The use of address groups should be kept to a minimum and never qualified. Address groups are used:
 - (1) In place of clear names and addresses in voice conversations and messages, except when referring to a station in the same unit or on the same net.
 - (2) As a temporary callsign, when a station joins a net for which he has no allocated callsign.
 - (3) To refer, as required, by implication and context headquarters to which the address group is allotted, or to the whole formation, unit or sub unit served by that headquarters.
- b. When used, address groups are pronounced phonetically and, except in the address component of a formal message,

218. CALLSIGNS

- a. A callsign is a combination of letters and figures that identify a communication facility, an organisation, or an individual on a radio net. Its primary use is to establish and maintain communications. The callsign system to be used on an Allied net will be specified by the appropriate command HQ communications staff.
- b. After the initial call between two stations, callsigns should be dropped altogether unless confusion is likely to arise by so doing. In different circumstances, some callsign systems allow users to abbreviate callsigns once communications have been established. Again, as an aid to COMSEC, the abbreviated callsign should be dropped whenever possible in communications between two stations unless confusion will arise in so doing.
- c. Full callsigns are to be used on the following occasions:
 - (1) When first establishing a net.

Released 5 September 2001

- (2) When reporting into a previous established net.
 - (3) In the transmission instructions and address components when a message is required to be relayed to a station on a different net.
- d. When secure daily changing callsigns are used for classified and unclassified message and unit or ship names appear in the text of an unclassified message, the unit or ships name is to be replaced by the relevant secure callsign or address group in full. Callsigns and address groups may be preceded by CALLSIGN or ADDRESS GROUP, as appropriate, when used in this manner.

Released 5 September 2001

UNCLASSIFIED

2-12

CHAPTER 3**ACCURACY****301. GENERAL**

Voice procedure is designed to provide the fastest and most accurate method of speech transmission. All messages should be pre-planned, brief and straightforward. Ideally, messages should be written down: even brief notes reduce the risk of error. Messages should be constructed clearly and logically in order not to confuse the recipient.

302. SPEECH TECHNIQUE

The correct use of audio equipment and clear, concise speech over the radio are essential if transmissions are to be successfully received and understood at the first attempt.

- a. Use of Audio Equipment. In many situations, particularly in noisy or difficult conditions, the use of headsets fitted with a noise cancelling microphone is preferable to loudspeakers: a headset will aid concentration and the audibility of the incoming signal. The double-sided, noise cancelling microphone is designed to cancel out surrounding noise, for example engine noise or gunfire, allowing speech entering on one side to pass freely. The microphone should be as close to the mouth as possible.
- b. Method of Speech. The key words to remember are Rhythm, Speed, Volume and Pitch (RSVP).
 - (1) Rhythm. Use short sentences divided into sensible phrases which maintain a natural rhythm; they should not be spoken word by word. Where pauses occur, the pressel should be released to minimize transmission time and permit stations to break in when necessary.
 - (2) Speed. Speak slightly slower than for normal conversation. Where a message is to be written down by the recipients, or in difficult conditions, extra time should be allowed to compensate for the receiving station experiencing the worst conditions. Speed of transmission is easily adjusted by increasing or decreasing the length of pauses between phrases, as opposed to altering the gaps between words; the latter will create an unnatural, halted style of speech, which is difficult to understand.

Released 5 September 2001

- (3) Volume. Speak quietly when using whisper facilities, otherwise the volume should be as for normal conversation. Shouting causes distortion.
- (4) Pitch. The voice should be pitched slightly higher than for normal conversation to improve clarity.

303. AIDS TO ACCURACY

- a. Pronunciation of Letters. To help identify spoken letters of the alphabet a standard phonetic word alphabet is used. Each letter of the alphabet is represented by a uniquely pronounced word to enable consistent and accurate pronunciation. For example, BRAVO is the phonetic equivalent of the letter B and DELTA equates to the letter D.
- b. Phonetic Alphabet. The following alphabet table shows the phonetic word equivalent of each Letter as it is written and then as it is spoken. The underlined portion of the spoken words indicates the syllables that require emphasis.

Letter	Phonetic	Spoken as	Letter	Phonetic	Spoken as
A	ALFA	<u>AL</u> -FAH	N	NOVEMBER	NO- <u>VEM</u> -BER
B	BRAVO	<u>BRAH</u> -VO	O	OSCAR	<u>OSS</u> -CAH
C	CHARLIE	<u>CHAR</u> -LEE	P	PAPA	PAH- <u>PAH</u>
D	DELTA	<u>DELL</u> -TAH	Q	QUEBEC	KEH- <u>BECK</u>
E	ECHO	<u>ECK</u> -OH	R	ROMEO	<u>ROW</u> -ME-OH
F	FOXTROT	<u>FOKS</u> -TROT	S	SIERRA	SEE- <u>AIR</u> -RAH
G	GOLF	GOLF	T	TANGO	<u>TANG</u> -GO
H	HOTEL	HOH- <u>TELL</u>	U	UNIFORM	<u>YOU</u> -NEE-FORM
I	INDIA	<u>IN</u> -DEE-AH	V	VICTOR	<u>VIK</u> -TAH
J	JULIETT	<u>JEW</u> -LEE- <u>ETT</u>	W	WHISKEY	<u>WISS</u> -KEY
K	KILO	<u>KEY</u> -LOH	X	XRAY	<u>ECKS</u> -RAY

Released 5 September 2001

UNCLASSIFIED

L	LIMA	<u>LEE</u> -MAH	Y	YANKEE	<u>YANG</u> -KEY
M	MIKE	MIKE	Z	ZULU	<u>ZOO</u> -LOO

- c. Pronunciation of Figures. Whenever figures are spoken in single digits over radio they are pronounced as shown in the following table. The underline portion of the spoken words indicates the letter or syllables requiring emphasis.

Figure	Spoken as	Figure	Spoken as
1	WUN	6	SIX
2	TOO	7	<u>SEV</u> -EN
3	TREE	8	AIT
4	<u>FOW</u> -ER	9	<u>NINE</u> -ER
5	FIFE	0	<u>ZE</u> -RO

304. RULES FOR SPELLING

- a. Plain Text. Spelling is necessary when difficult radio conditions prevent the reception of an obscure word, or of a word or group, which is unpronounceable. Such words or groups within the text of plain language messages may be spelt using the phonetic alphabet; they are preceded by the proword "I SPELL". If the word is pronounceable and it is advantageous to do so, then it should be spoken before and after the spelling to help identify the word.

Example 1. Pronounceable word – UNNA: ..."UNNA- I spell, Uniform November November Alfa".

Example 2. Unpronounceable word or group – UTFX: ..."I spell, Uniform Tango Foxtrot Xray".

- b. Exceptions to this rule, when letters are always spoken phonetically wherever they appear, and without the proword I SPELL are:
- (1) Callsigns and Net Identification Signs (NIS)
 - (2) Grid references (UTMs).

- (3) Target indications
- (4) Authentication.
- (5) DTG zone suffix/SICs.
- (6) Address groups.
- (7) Encrypted text.

305. ENCRYPTED TEXT

On insecure nets, when a text, or portion of text is encrypted, the letter and figure groups are always to be spelt phonetically without the proword I SPELL.

Example. Encrypted portion of text. 2S BJ MW IF: ... "TWO SIERRA – BRAVO JULIETT – MIKE WHISKEY – INDIA FOXTROT".

306. RULES FOR FIGURES

- a. When radio conditions are satisfactory and confusion will not arise, figures in the text of a message may be spoken as in normal speech. During difficult conditions, or when extra care is necessary to avoid misunderstanding, figures are sent digit by digit preceded by the proword FIGURES. This proword warns that figures follow immediately, to help distinguish them from other similarly pronounced words.

Examples:

Figure	Satisfactory conditions	Difficult conditions
23	Twenty three	FIGURES two three
50	Fifty	FIGURES five zero
146	One hundred and forty six	FIGURES one four six
200	Two hundred	FIGURES two zero zero
1009	One thousand and nine	FIGURES one zero zero nine

Released 5 September 2001

UNCLASSIFIED

1630 hours Sixteen thirty hours FIGURES one six three zero
hours

2800 Two thousand eight hundred FIGURES two eight zero
zero

12000 Twelve thousand FIGURES one two zero zero
zero

b. Exceptions to this rule, when figures are always spoken digit by digit whenever they appear, and without the proword FIGURES are:

- (1) Callsigns
- (2) Grid references.
- (3) Target indications (except that exact multiples of a hundred or a thousand are pronounced as such).
- (4) Authentication
- (5) Formal message date time groups (DTGs).

307. RULES FOR MIXED GROUPS

The rules for sending mixed letter/figure groups incorporate the same principles that apply to sending letters and figures separately. The same information may be sent in two different ways depending on the circumstances.

Example 1. Satisfactory conditions:

Mixed group	spoken as
ACP 125	ACP one two five

Example 2. Difficult conditions:

Mixed group	spoken as
ACP 125	I SPELL ALFA CHARLIE PAPA FIGURES one two five

308. AIDS TO BREVITY

- a. Abbreviations. Although originally designed to save time in writing, abbreviations will often save time in speech. Many abbreviations are so commonly used in normal speech they are more familiar than their original unabbreviated form. The use of such abbreviations in radio transmissions is to be encouraged provided that:
 - (1) They are quicker and easier to use than the full word.
 - (2) They are sufficiently well known to avoid any confusion and subsequent confirmatory transmissions.
 - (3) Where an abbreviation has more than one meaning, the intended meaning is obvious to the addressee from its context or frequent usage.
- b. Whether abbreviations are spoken as such, spelt phonetically or expanded to their unabbreviated form, will depend on prevailing radio conditions and the circumstances in which they are used. The following common sense rules should be applied to take account of conditions:
 - (1) Satisfactory Conditions. To ensure that the advantage of brevity which abbreviations provide is not lost, they will be spoken as in normal speech.

Examples:

RV as RV instead of "I spell Romeo Victor".

DR as DR instead of "I spell Delta Romeo".

ETA as ETA instead of "I spell Echo Tango Alfa".

- (2) Difficult Conditions. In conditions which require amplification of common abbreviations normally spoken as such, it is usually quicker and easier to use the full word than to waste time and effort in spelling.

Examples:

Dispatch Rider is better than "I spell Delta Romeo".

Recce (reconnaissance) is better than "I spell Romeo Echo Charlie Charlie Echo".

Released 5 September 2001

UNCLASSIFIED

- c. Abbreviations should only be spelt phonetically when it is either quicker and easier to do so, or the spelling will be more readily received and understood than the full word or phrase. Examples where spelling is more appropriate than the full words are:

“I spell November Bravo Charlie” instead of “Nuclear Biological and Chemical”.
 “I spell Papa Oscar Lima” instead of Petrol, Oil and Lubricants.

“I spell Uniform Tango Mike” instead of Universal Transverse Mercator.

- d. Where necessary the sender of a message may, on behalf of the drafter, expand common abbreviations during difficult conditions or when a transmission can be simplified. Where any doubt exists as to the drafter’s intentions, abbreviations should never be expanded but spelt phonetically leaving the addressee to interpret the meaning. The abbreviation DF can mean “Defensive Fire” or “Direction Finding”; if the intended meaning is not obvious then DF should be spelt phonetically.

- e. Procedure Words (Prowords). To keep voice transmissions as brief and clear as possible standard prowords are used in place of whole sentences. Prowords are easily pronounced and recognised words or phrases used to convey a specific predetermined meaning, for example:

<u>Proword</u>	<u>Meaning</u>
ROGER	I have received your last transmission satisfactorily
OUT	This is the end of my transmission to you and no answer is required or expected

A full list of prowords is given at Annex A to this chapter

- f. Punctuation. Punctuation is not to be used unless it is necessary to the sense of a message, and should rarely be required in radio messages where the originator makes his own transmission. Punctuation can occur more often in written informal or formal messages. When the use of punctuation is essential, it should be written and spoken as follows:

Punctuation	Spoken as	Symbol or Abbreviation
Full stop/period	Full stop	. PD
Comma	Comma	, CMM

Slant/Oblique	Slant	/	
Hyphen	Hyphen	-	
Left-hand bracket	Brackets on	(Paren
Right-hand bracket	Brackets off)	Unparen
Colon	Colon	:	CLN
Semi-colon	Semi-colon	;	SMCLN
Question Mark	Question mark	?	Ques
Decimal point	Day-See-Mal	.	Point

g. Brevity Codes. Messages transmitted in a set format, including data messages, may be shortened through the use of brevity codes. A brevity code is a list of numbers or letter, which equate to a standard pre-determined vocabulary of words or phrases, for example equipment and commodity codes. Brevity codes can reduce long stereotyped sentences or lists to a few characters and save considerable time in transmission. It is however important to remember that such codes provide no security at all, and must be regarded as the equivalent of plain language when transmitted unencoded over radio.

h. Nicknumbers. A nickname is a two figure group which may be used on forward tactical nets to describe;

Bridges	Rivers
Reserved Demolitions	Place names
Road Junctions	Report Lines
Stop Lines	Killing Areas
Counter Attack/Penetration Areas	

and any other prominent features which need to be disguised. They have NO SECURITY VALUE and are ALWAYS TO BE ENCODED. They are introduced by the Proword NICK.

Released 5 September 2001

UNCLASSIFIED

- i. Writing Abbreviations and Symbols:
 - (1) When writing, symbols should always be used in preference to abbreviations, with the symbols for full stops and commas ringed to make them more conspicuous.
 - (2) If punctuation marks other than those described are vital to the sense of the text, they are to be written in full, eg APOSTROPHE, QUOTE, UNQUOTE and spoken as such.

309. LEGIBILITY OF CHARACTERS

Legible writing is essential if handwritten messages are to be transmitted and received accurately. All handwritten messages drafted for transmission are to be written in capital letters, The following conventions for written characters and symbols are to be observed when drafting and receiving messages:

- a. The figure ZERO is written with a slant through it to distinguish is from the letter OSCAR.
- b. The figure ONE is written with a line underneath to distinguish it from the letter LIMA.
- c. The letter ZULU is written with a hyphen through it to distinguish it from the figure TWO.

LIST OF PROWORDS AND THEIR EQUIVALENT PROSIGNS OR OPERATING SIGNALS

Proword	Explanation	Prosign/ OPSIG
ACKNOWLEDGE (ACK)	An instruction to the addressee that the message must be acknowledged	ZEV or QSL
ADDRESS GROUP	The group that follows is an address group	
ALL AFTER	The portion of the message to which I have reference is all that follows.....	AA
ALL BEFORE	The portion of the message to which I have reference is all that precedes.....	AB
ANSWER AFTER	The station called is to answer after call sign..... when answering transmissions.	ZGO
ASSUME CONTROL	You will assume control of this net until further notice	ZKD
AUTHENTICATE	The station called is to reply to the challenge which follows	INT ZNB
AUTHENTICATION IS	The transmission authentication of this message is.....	ZNB
BREAK	I hereby indicate the separation of the text from other portions of the message	BT
BROADCAST YOUR NET	Link the two nets under your control for automatic rebroadcast	
CALL SIGN	The group that follows is a call sign	
CLOSE DOWN	Stations are to close down when indicated. Acknowledgments are required	ZKJ
CORRECT	You are correct, or what you have transmitted is correct.	C
CORRECTION	An error has been made in this transmission. Transmission will continue with the last word correctly transmitted.	EEEEEEEE
	An error has been made in this transmission (or message indicated). The correct version is.....	C
	That which follows is a corrected version in answer to your request for verification	C
DISREGARD THIS TRANSMISSION –	This transmission is in error, disregard it. (This proword shall not be used to cancel any message that	EEEEEEEE AR

Released 5 September 2001

UNCLASSIFIED

UNCLASSIFIED

ACP 125 (F)

Proword	Explanation	Prosign/ OPSIG
OUT	has been completely transmitted and receipted.	
DO NOT ANSWER	Stations called are not to answer this call, receipt for this message, or otherwise transmit in connection with this transmission. When this proword is employed, the transmission shall be ended with the proword OUT.	F
EXECUTE	Carry out the purport of the message or signal to which this applies. (To be used only with the Executive Method.)	IX-----
EXECUTE TO FOLLOW	Action on the message or signal which follows is to be carried out upon receipt of the proword EXECUTE. (To be used only with the Delayed Executive Method.)	IX
EXEMPT	The station(s) immediately following is (are) exempted from the collective call or from collective address	XMT
FIGURES	Numerals or numbers follow.	
FLASH	Precedence FLASH.	Z
FROM	The originator of this message is indicated by the address designator immediately following	FM
GRID	The portion following is a grid reference	
GROUPS	This message contains the number of groups indicated by the numeral following.	GR
GROUP NO COUNT	The groups in this message have not been counted.	GRNC
I AM ASSUMING CONTROL	I am assuming control of this net until further notice	ZKA
I AUTHENTICATE	The group that follows is the reply to your challenge to authenticate	ZNB
IMMEDIATE	Precedence IMMEDIATE	O
IMMEDIATE EXECUTE	Action on the message or signal following is to be carried out on receipt of the EXECUTE. (To be used only with the Immediate Executive Method.)	IX
INFO	The addressees immediately following are addressed for information	INFO
I READ BACK	The following is my response to your instructions to read back	IRB
I SAY AGAIN	I am repeating transmission or portion indicated.	IMI
I SPELL	I shall spell the next word phonetically.	
I VERIFY	That which follows has been verified at your request and is repeated. (To be used only as a reply to VERIFY.)	C
MESSAGE	A message which requires recording is about to follow. (Transmitted immediately after the call.	ZBO

Released 5 September 2001

UNCLASSIFIED

Proword	Explanation	Prosign/ OPSIG
	This proword is not used on nets primarily employed for conveying messages. It is intended for use when messages are passed on tactical or reporting nets.)	
MORE TO FOLLOW	Transmitting station has additional traffic for the receiving station.	B
NEGATIVE (NEGAT)	No. Cancel message(s) sent by the Delayed Executive Method. (NEGAT may be used to cancel a single message or a group of messages awaiting execution.)	ZUG
NET NOW	All stations are to net their radios on the unmodulated carrier wave which I am about to transmit.	ZRC2
NO PLAY	During exercises the words NO PLAY are used to distinguish real activity from messages concerned with exercise play e.g. a real emergency or real casualty. The first words of any message is to contain the works exercise (nickname e.g.Red Flag) NO PLAY	
NOTHING HEARD	To be used when no reply is received from a call station.	ZGN
NUMBER	Station serial number.	NR
OUT	This is the end of my transmission to you and no answer is required or expected.	AR
OVER	This is the end of my transmission to you and a response is necessary. Go ahead, transmit	K
PRIORITY	Precedence PRIORITY	P
READ BACK	Repeat this entire transmission back to me exactly as received	G
REBROADCAST YOUR NET	Link the two nets under your control for automatic rebroadcast.	
RELAY (TO)	Transmit this message to all addressees (or addressees immediately following this proword). The address component is mandatory when this proword is used.	T or ZOF
RELAY THROUGH	Relay your message through call sign.....	ZOK
ROGER	This is a method of receipt. I have received your last transmission satisfactorily.	R
ROUTINE	Precedence ROUTINE.	R
SAY AGAIN	Repeat all of your last transmission. Followed by identification data means "Repeat..... (portion indicated)."	IMI
SEND YOUR	I am ready to receive your message, report, etc. (Used only in reply to the offer of a message, etc., on	K

Released 5 September 2001

UNCLASSIFIED

UNCLASSIFIED

ACP 125 (F)

Proword	Explanation	Prosign/ OPSIG
	tactical or reporting nets.)	
SERVICE	The message that follows is a SERVICE message	SVC
SIGNALS	The groups which follow are taken from a signal book. (This proword is not used on nets primarily employed for conveying signals. It is intended for use when tactical signals are passed on non-tactical nets.)	
SILENCE (Repeated three or more times)	Cease transmissions on this net immediately. Silence will be maintained until lifted. (Transmissions must be authenticated by use of a self authenticated system, codeword, etc.)	HM HM HM
SILENCE LIFTED	Silence is lifted. (Transmissions must be authenticated by means of self authentication system, codeword, etc.)	ZUG HM HM HM
SPEAK SLOWER	Your transmission is too fast. Reduce speed of transmission.	QRS
STOP REBROADCASTING	Cut the automatic link between the two nets that are being rebroadcast and revert to normal working.	
THIS IS	This transmission is from the station whose designator immediately follows.	DE
THIS IS A DIRECTED NET	From now until further notice this net is directed.	ZKB
THIS IS A FREE NET	From now until further notice this net is directed.	ZUG ZKB
THROUGH ME	Relay your message through me	ZOE
TIME	That which immediately follows is the time or date-time group of the message.	QTR
TO	The addressees immediately following are addressed for action	TO
--TO--	The portion of the message to which I have reference is all that which appears between the groups.....and.....	
UNKNOWN STATION	The identity of the station with whom I am attempting to establish communication is unknown.	AA
USE ABBREVIATED CALL SIGNS	Call signs are to be abbreviated until further notice.	
USE ABBREVIATED PROCEDURE	As conditions are normal, all stations are to use abbreviated procedure until further notice.	
USE FULL CALL SIGNS	Call signs are to be sent in full until further notice	
USE FULL	As conditions are not normal, all stations are to use	

Released 5 September 2001

UNCLASSIFIED

Proword	Explanation	Prosign/ OPSIG
PROCEDURE	full procedure until further notice.	
VERIFY	Verify entire message (or portion indicated) with the originator and send correct version. (To be used only at the discretion of, or by, the addressee to which the questioned message was directed.)	J
WAIT	I must pause for a few seconds	AS
WAIT – OUT	I must pause for longer than a few seconds.	AS AR
WILCO	I HAVE RECEIVED YOUR SIGNAL, UNDERSTAND IT, AND WILL COMPLY. To be used only by the addressee. Since the meaning of ROGER is included in that of WILCO, the two prowords are never used together.	
WORD AFTER	The word of the message to which I have reference is that which follows.....	WA
WORD BEFORE	The word of the message to which I have reference is that which precedes.....	WB
WORDS TWICE	Communication is difficult. Transmit each phrase (or each code group) twice. (This proword may be used as an order, request, or as information.)	QSZ
WRONG	Your last transmission was incorrect. The correct version is.....	ZWF

Released 5 September 2001

UNCLASSIFIED

CHAPTER 4
DISCIPLINE

401. GENERAL

- a. Radio discipline is a fundamental ingredient of voice procedure without which a radio net cannot function efficiently. In addition to reducing communications efficiency and accuracy, inadequate radio discipline can result in a serious degradation of security standards.
- b. It is the commander's responsibility to impose and maintain discipline on a radio net. A commander may choose to exercise that responsibility through the control station. All radio nets or links must have a designated control station. In the absence of instructions to the contrary, the control station is that station serving the senior headquarters or location.
- c. During difficult conditions, net efficiency can deteriorate even more rapidly if the control station permits poor operating standards.

402. RULES FOR RADIO DISCIPLINE.

The following rules for radio discipline are mandatory on all radio nets. Every station must adhere to the following.

- a. Always:
 - (1) Use correct voice procedure.
 - (2) Maintain a constant listening radio watch unless specific instructions or permission has been received to the contrary. This requires that at least one person be nominated to monitor the radio regardless of the circumstances. All aspects of voice procedure are based on the assumption that stations will respond to the call immediately.
 - (3) Ensure that the correct frequency is in use.
 - (4) Answer calls in the correct order and without delay.
 - (5) Listen carefully before transmitting to ensure that the frequency is clear and, where possible allow for stations which cannot be heard.
 - (6) Release the pressel switch promptly.
 - (7) On releasing the pressel switch, ensure that the radio returns to the receive condition.
- b. Never:
 - (1) Violate radio silence.
 - (2) Compromise classified information by unauthorised plain language disclosure.
 - (3) Make unnecessary or unduly long transmissions.
 - (4) Engage in unofficial conversation or operator's chat.
 - (5) Identify an individual, ship or unit by name, or any other personal or individual sign.

Released 5 September 2001

- (6) Speak faster than the station experiencing the worst reception conditions can be expected to receive, thus avoiding needless repetition.
- (7) Show loss of temper or resort to profane language.

403. RADIO LOGGING

- a. Whenever practical to do so, radio logs are to be maintained on all radio nets. Not all types of stations will be able to keep a full log. The operator in an armoured fighting vehicle is not expected to maintain a log as neatly or completely as say a watchkeeper in a ship or headquarters who is dedicated to a single task.
- b. Subject to the above, the radio log should contain a complete and continuous record of all transmitted and received messages, and information concerning the radio net. The log should be written legibly in the operator's own hand, and include all relevant details and timings of the following:
 - (1) All transmitted and received informal messages and voice conversations in full or, where this is impractical, the gist of a message in sufficient detail to provide adequate reference information. Operators should attempt to log messages between other users of the radio net, but it is accepted that the logging of traffic between third parties is likely to be of second priority during busy periods.
 - (2) The identity of formal messages written separately on a message form.
 - (3) The opening and closing of the radio stations on the net.
 - (4) Changes in operating frequency and interference reports.
 - (5) Sufficient reference data to identify all other calls or procedural messages transmitted or received on the net.
 - (6) Entries to the effect that the radio receiver is operating correctly in thereceive condition. (These should be made at regular intervals during periods of net inactivity.)
 - (7) Reports of stations with whom contact is difficult or suspect, amplified with any corrective action taken.
 - (8) Unusual occurrences such as procedural or security violations, or suspected deception or jamming. Entries should include the reporting action taken.

Released 5 September 2001

UNCLASSIFIED

- (9) Handover and takeover by the radio station operators. The receiving operator is to record his rank, name and signature to the effect that the transfer has been completed satisfactorily. Unless other arrangements exist, this signature is also to confirm that a complete check of any classified material has been made.

- c. Good log keeping is an essential part of the efficient operation of a radio station, particularly at Control where the operator is responsible for other stations on the net.

- d. Radio logs to be held in safe keeping in accordance with national / theatre / command instructions.

THIS PAGE INTENTIONALLY BLANK

Released 5 September 2001

UNCLASSIFIED

4-4

CHAPTER 5**MESSAGES****501. PLAINDRESS**

- a. A plaindress message is one in which the originator and addressee designators are indicated externally of the text.
- b. A plaindress message contains all the components (unless the call serves as the address) as shown in the basic message format and must always include the precedence and date-time group.
- c. The group count will always be included when the accounting symbol is employed.

502. ABBREVIATED PLAINDRESS

- a. Operational requirements for speed of handling may require abbreviation of plaindress headings. In such case, any or all of the following may be omitted:
 - (1) Precedence.
 - (2) Date.
 - (3) Date-time group.
 - (4) Group count.

503. CODRESS

A codress message is one in which the entire address (i.e., originator and all addressees, including address indicating groups when used), is encrypted within the text. The heading of such a message contains only information necessary to enable communication personnel to handle it properly. It contains all other components shown in the schematic diagram, paragraph 510.

504. SERVICE MESSAGE

- a. A service message is one between communications personnel and pertaining to any phase of traffic handling, communications facilities, or circuit conditions.
- b. An encrypted service message will always carry a numerical group count and will be identified as a service message only within the encrypted text.
- c. Plain-language service messages are identified by the proword SERVICE (paragraph 517).
- d. Service messages may be prepared and transmitted in plaindress, abbreviated plaindress, or codress form. They generally concern messages originated at, destined for, or refiled by, the station originating the service message, and will normally be assigned a precedence equal to that of the message to which they refer.

505. ABBREVIATED SERVICE MESSAGE

An abbreviated service message is one between operators, which may be required to facilitate traffic handling. This type of message contains only prowords, address designators, identification of messages, parts of messages, and amplifying data as necessary. An abbreviated service message may be transmitted using plaindress or abbreviated plaindress procedure. It is not identified and need not be authorised in the same manner as a service message.

506. INFORMAL MESSAGES

Informal messages are those tactical, operational and service messages commonly sent on user operated circuits, e.g., field tactical and air control. These types of traffic tend to utilise a more conversational procedure. Informal messages tend to contain any element of the basic message format (table in paragraph 510), however, they will normally only consist of a call, a text, and an ending, i.e., format lines 2, 3, 12 and 15. All elements used are to be in the sequence described in the basic message format, and when used, time groups sent in format line 14 would normally be time of transmission rather than time of origin.

Released 5 September 2001

UNCLASSIFIED

507. CLASSIFICATION OF SERVICE AND ABBREVIATED SERVICE MESSAGES

- a. An unclassified service or abbreviated service message may be used when referring to a classified message if only prowords and message or transmission identifications are used. If it is necessary to include anything that would reveal part of the plain language text of the classified message, however, the service or abbreviated service message must be classified.
- b. An unclassified service or abbreviated service message referring to a message received in codress form, or using encrypted call signs or address groups, shall use only those message or transmission identifications which were contained in the external message heading as received.

508. LONG MESSAGE PROCEDURE

Long Message Procedure is required to reduce time spent on the air and allow another station to break in with precedence traffic if required. Transmission length should be no longer than 20 seconds in any one transmission.

Example:

Nine Two – THIS IS – Six Nine – Long Message – OVER

THIS IS – Nine Two – Send – OVER

THIS IS – Six Nine – Text (transmit for 20 seconds maximum)– ROGER so far – OVER

THIS IS – Nine Two – ROGER – OVER

Six Nine pauses for approximately 5 seconds to allow another station to break in if required.

THIS IS – Six Nine – Text (continue with remainder of message, again transmitting in 20 second periods repeating the procedure as necessary to transmit the entire message). – OVER

On completion of entire transmission receiving station (Nine Two) will receipt, obtain repetitions or confirmations as necessary as normal.

509. MESSAGE FORMAT

Each message shall be prepared in plaindress, abbreviated plaindress, or codress form except when a commercial or International Civil Aviation Organisation form is authorised.

- a. Each message prepared in either plaindress, abbreviated plaindress, or codress will have three PARTS:
 - (1) Heading.
 - (2) Text.
 - (3) Ending.
- b. Each message PART has certain COMPONENTS which are broken down into ELEMENTS and CONTENTS.
 - (1) All message PARTS and a majority of the COMPONENTS and ELEMENTS have a standardised arrangement or sequential order of appearance.
 - (2) In the schematic diagram (paragraph 510), format lines 2, 3, 4, 14, and 16 identify the procedural portion of the basic message format as designed for radiotelephone operation. Lines 5 through 13 are the unchangeable elements of the basic format. Not all format lines necessarily appear in every message; however, when used, they will be in the order indicated.

510. SCHEMATIC DIAGRAM OF MESSAGE FORMAT

In the following diagram, note that every ELEMENT is indicated in the order of appearance in the message, but the contents of the various ELEMENTS are not necessarily indicated, as they will appear.

PART	COMPONENT	ELEMENT	FORMAT LINE	CONTENT
Heading	Procedure		1	Not used.
		a. Call	2 & 3	Stations Called.
				Proword INFO, to identify info addressees

Released 5 September 2001

UNCLASSIFIED

UNCLASSIFIED

ACP 125 (F)

				in abbreviated plaindress messages. Proword EXEMPT, to identify exempted addressees. Proword THIS IS, to identify the station calling.
		b. Message follows		Proword MESSAGE
		c. Transmission Identification		Proword NUMBER and station serial number
		d. Transmission Instructions	4	Prowords. RELAY TO, READ BACK, DO NOT ANSWER, WORDS TWICE; operating signals, address groups, call signs, plain language designators.
	Preamble	a. Precedence, Date-Time Group, Message Instructions	5	Precedence designation, Proword TIME; date and time expressed in digits, and zone suffix, month indicated by the first three letters, and, if required by national authorities the year indicated by the last two digits, operating signals and proword EXECUTE TO FOLLOW or IMMEDIATE EXECUTE.
	Address	a. Originator	6	Proword FROM. Originator's address designator.
		b. Action Addressees	7	Proword TO. Action addressees designators.
		c. Information Addressees	8	Proword INFO. Information addressees designators.
		d. Exempted Addressee	9	Proword EXEMPT. Exempted addressees

Released 5 September 2001

				designators.
	Prefix	a. Accounting Information, Group count	10	Accounting symbol; group count; Proword GROUPS (GROUP NO COUNT).
Separation			11	Proword BREAK
Text	Text	a. Subject Matter	12	CLEAR, UNCLASSIFIED, proword SERVICE, and/or internal instructions as appropriate; thoughts or ideas as expressed by the originator.
Separation			13	Proword BREAK
Ending	Procedure	a. Time Group	14	Proword TIME. Hours and minutes expressed in digits and zone suffix, when appropriate.
		b. Final Instructions	15	Prowords AUTHENTICATION IS, CORRECTION, I SAY AGAIN, MORE TO FOLLOW, STANDBY EXECUTE, WAIT; operating signals, address groups; call signs; and plain language designators.
		c. Ending Sign	16	Prowords OVER, OUT.

511. FORMAT LINES 2 AND 3 (CALLING AND ANSWERING)

- a. These lines will contain the call, the proword MESSAGE, and the transmission identification
- b. The Call. The call of a message serves to identify the stations between which that particular message is being transmitted. It may also serve as the address of the message when the designators of the originator and

Released 5 September 2001

UNCLASSIFIED

UNCLASSIFIED

ACP 125 (F)

addressees are the same as the call signs of the stations in communication with each other on the same circuit.

c. The call may take one of the following forms:

(1) Full Call

Yankee One Three Charlie - Call sign of receiving station

THIS IS - From

Zulu Three Four Delta - Call sign of transmitting station

(2) Abbreviated Call. The call sign of the called station may be omitted when a call is part of an exchange of transmissions between stations and no ambiguity will result.

THIS IS - From

Sabine Raider - Call sign of transmitting station

(3) For speed of working when conditions are good, particularly on large nets, the receiving station may omit the proword THIS IS when responding to a call or receipting for a transmission.

(4) When two stations are in continuous communication with each other on a net not shared by a third station, the call may be omitted entirely, provided no confusion would result. For ground forces use, this provision may apply to any two stations within the same net which are in continuous communications with each other. However, in either of the foregoing instances, the requirement for periodic identification as set forth in appropriate national and/or international regulations must be adhered to, as far as possible.

(5) An aeronautical station may acknowledge an aircraft message by transmitting the identification of the aircraft.

d. The call may contain:

(1) Individual call signs identifying stations (addressees) separately.

Released 5 September 2001

UNCLASSIFIED

- (2) Collective call signs identifying a predetermined group of stations (addressees).
 - (3) A combination of both individual and collective call signs.
 - (4) Net call sign identifying all stations on a given net.
- e. The call may be of two types:
- (1) Single call – only one call sign precedes the proword THIS IS. This may be an individual, collective or net call sign.

Example:

Using an individual call sign.

Delta Three Eight One this Zulu Three Four Delta – OVER

- (2) Multiple call – two or more call signs precede the proword THIS IS. These may be individual and/or collective and/or net call signs.

Example:

Using two individual call signs.

Damp Lion – Hollow Piston THIS IS Sabine Raider – OVER

- f. When the call serves as the address and a collective call sign is used and there are exempted addressees in the message, such addressees can be exempted in the call by use of the proword EXEMPT followed by the call sign of the stations exempted.

Example:

Yankee One Three Charlie EXEMPT Foxtrot One Seven Eight THIS IS Zulu Three Four Delta – OVER

- g. Message – The proword MESSAGE may be transmitted immediately following the call to indicate that a message that requires recording is about to follow.
- h. Transmission Identification – A transmission identification is not normally used on voice nets but, if required, it will be the last element of format

Released 5 September 2001

UNCLASSIFIED

5-8

UNCLASSIFIED

ACP 125 (F)

lines 2 and 3 and will consist of the station serial number preceded by the
proword NUMBER.

Released 5 September 2001

UNCLASSIFIED

5-9

512. FORMAT LINE 4 (TRANSMISSION INSTRUCTIONS)

This line contains the transmission instructions which may consist of prowords WORDS TWICE, RELAY (TO), DO NOT ANSWER, or READ BACK. The use of these prowords is explained in paragraphs 613b, 614, 619 and 620.

513. FORMAT LINE 5 (PREAMBLE)

This line will contain the precedence, date-time group, and message instructions:

- a. Precedence – The appropriate precedence designation is transmitted as the first element of format line 5. In the case of dual-precedence messages, the higher precedence designation will be transmitted first.
- b. Date-Time Group – The proword TIME followed by the date-time group and zone suffix, month indicated by the first three letters and if required by national authorities, the year indicated by the last two digits is transmitted immediately after the precedence designation. An abbreviated plaindress message may carry no date-time group, or a time group transmitted in line 14 may replace the date-time group.

Example:

Hotel Seven Nine Five – THIS IS Alfa One Nine Two – RELAY TO Bravo Four Two Zero – PRIORITY – TIME Zero Seven One Six Three Zero Zulu.....

- c. Message Instructions – These should not normally be required on radiotelephone messages. When included, they will consist of short and concise instructions, which will remain with the message to the station of destination.

Example:

THIS MESSAGE IS A SUSPECTED DUPLICATE

514. FORMAT LINES 6, 7, 8 AND 9 (ADDRESS)

These lines form the address of the message and are recognised by the prowords FROM, TO, INFO and EXEMPT, respectively. When the originator and the addressees are in communication with each other on the same circuit, the call will serve as the address.

Released 5 September 2001

UNCLASSIFIED

Example A:

Plaindress message heading showing all possible elements of the address component (assuming abbreviated call signs are in use):

Transmission	Explanation
Three Charlie.....	Collective call sign of stations called
THIS IS.....	From
Four Delta.....	Call sign of station calling
MESSAGE.....	A message that requires recording is about to follow
PRIORITY.....	Precedence designation
TIME.....	The time of origin is
One Two	
One Six	
Thee Zero	
Zulu JAN.....	Date-time group (121630Z JAN)

Address

FROM.....	The originator of this message is
Four Delta.....	Call sign of originator
TO.....	The action addressee is
Three Charlie.....	Collective call sign of action addressees
INFO.....	The information addressee is
Two Zero.....	Call sign of information addressee is
EXEMPT.....	The exempted addressee is
Seven Eight.....	Call sign of exempted addressee

Example B:

Abbreviated plaindress message showing three elements in the address component (assuming abbreviated call signs are in use):

Transmission	Explanation
Eight One.....	Call sign of receiving station
THIS IS.....	From
Zero Six.....	Call sign of calling station

Address

FROM.....	The originator of this message is
Zero Six.....	Call sign of originator
TO.....	The action addressee is

Two Zero.....Call sign of action addressee (not on net)
 INFO.....The information addressee is
 Eight one.....Call sign of information addressee

Example C:

Abbreviated plaindress message with call sign serving as the address, action addressees only (assuming abbreviated call signs are in use):

Transmission	Explanation
	Call and address
Oven.....	Call sign of receiving station and action addressee
THIS IS.....	From
Piston.....	Call sign of station calling and originator of the message
PRIORITY.....	Precedence designation
Text.....	Subject matter
TIME.....	Time of origin is
One Two	
Three Four Zulu.....	Time group

Example D:

Abbreviated plaindress message with the call sign serving as the address, action and information addressees (assuming abbreviated call signs are in use):

Transmission	Explanation
	Call and address
Six Nine.....	Call sign of station called and action addressee
INFO.....	The information addressee is
Eight One.....	Call sign of station called and information addressee
THIS IS.....	From
Zero Six.....	Call sign of station calling and originator of the message
Text.....	Subject matter
TIME.....	Time of origin is
One Eight	
Two Four Zulu.....	Time group

Released 5 September 2001

UNCLASSIFIED

Note: When the call sign serves as the address, a full call sign is mandatory when transmitting the message even though a preliminary call may have been used to ascertain that stations were ready to receive.

515. FORMAT LINE 10 (PREFIX)

- a. This line is identified by the proword **GROUPS** followed by the number of groups, or **GROUPS NO COUNT**. It may contain an accounting symbol in addition to the group designation.
 - (1) Accounting Information – Accounting symbols are seldom used on messages transmitted over radiotelephone circuits. However, they may appear on messages received for relay from circuits employing other procedures and should be recognised as such. These accounting symbols are a combination of letters used to indicate the agency, service, or activity, which assumed financial responsibility for the message.
 - (2) Group Count – Radiotelephone messages are usually short and a group count is seldom used. However, the number of groups if sent will be preceded by the proword **GROUPS** and will normally appear in the message prefix. When a message is transmitted before the group count is determined, the prowords **GROUPS NO COUNT** will be used in lieu of the group count. The actual group count may then be transmitted in the final instructions and be inserted in the message prefix by the receiving operator. The prowords **GROUPS NO COUNT** will be included in messages bearing an accounting symbol when groups are not counted.
- b. Some tactical codes require that the group count be transmitted at the end of the text rather than in format line 10. In such cases, format line 10 is not used and the group count is transmitted in accordance with the operating instructions for the code.

516. FORMAT LINE 11 (SEPARATION)

This line contains the proword **BREAK**, separating the text from the heading. It is used only when confusion between the heading and the text is likely.

517. FORMAT LINE 12 (TEXT)

This is the text of the message and may contain, prior to the thoughts or ideas as expressed by the originator, the word UNCLASSIFIED or the word CLEAR if specifically authorised (ACP121), the proword SERVICE, and internal instructions.

518. FORMAT LINE 13 (SEPARATION)

This line contains the proword BREAK, separating the text from the ending. It is used only when confusion between the text and the ending is likely.

519. FORMAT LINE 14 (TIME GROUP)

This line is used only in abbreviated plaindress messages when a time group transmitted here takes the place of a date-time group in line 5. It consists of the proword TIME followed by the time group plus the zone suffix.

520. FORMAT LINE 15 (FINAL INSTRUCTIONS)

May contain prowords (such as AUTHENTICATION IS, CORRECTION, I SAY AGAIN, MORE TO FOLLOW, STANDY EXECUTE, WAIT) operating signal, address groups, call signs, and plain-language designators.

521. FORMAT LINE 16 (ENDING SIGN)

This line is identified by the prowords OVER or OUT:

- a. Every transmission shall end with either the proword OVER or the proword OUT, except that the proword OVER may be omitted when two stations are in continuous communication with each other on a net not shared with a third or, in the case of ground forces, where two stations within the same net are in continuous communication with each other where confusion will not arise.
- b. In all transmissions where the proword DO NOT ANSWER is used, the transmission shall be ended with the proword OUT.

Released 5 September 2001

UNCLASSIFIED

CHAPTER 6

OPERATING RULES

601. GENERAL

- a. To use circuit time more efficiently, all messages or their substance should be written down prior to transmission. Those messages which must be delivered by the receiving operator to another person, or which are preceded by the proword MESSAGE, shall be written down.
- b. Transmissions by radiotelephone shall be as short and concise as practicable, consistent with clarity. The use of standard phraseology enhances brevity.
- c. Radio telephone transmissions should be clear, with natural emphasis on each word except the prescribed pronunciation of a numeral, and should be spoken in natural phrases, not word by word.
- d. If it is technically practical, the operator shall, during the transmission of a message, pause after each natural phase and interrupt his transmission (carrier) momentarily, to allow another station to break in if necessary.
- e. To avoid interfering with other traffic, an operator shall listen to make certain that a circuit is clear before making any transmission.
- f. When it is necessary for a station to initiate test signals, either for the adjustment of a transmitter before making a call or for the adjustment of a receiver, such signals will not continue for more than 10 seconds and will be composed of spoken numerals (1, 2, 3 etc.) followed by the call sign of the station transmitting the signals.

602. AUTHENTICATION

When authentication is required, it will be carried out in accordance with the authentication system in force.

603. ESTABLISHING COMMUNICATIONS

- a. Full call signs must be used when establishing communications.
- b. Before passing traffic it may be necessary to establish the reception conditions for all stations.

Example A (Good conditions):

Z34D transmits:

Alfa One Nine Two – THIS IS Zulu Three Four Delta – OVER

A192 answers the initial call:

THIS IS Alfa one Nine Two

Z34D having nothing for A192, transmits:

Alfa One Nine Two – THIS IS Zulu Three Four Delta – OUT.

Example B (Difficult conditions);

Z34D transmits:

Alfa One Nine Two – Alfa One Nine Two – THIS IS Zulu Three Four Delta – Zulu Three Four Delta – RADIO CHECK – OVER

A192 transmits:

Zulu Three Four Delta – Zulu Three Four Delta – THIS IS Alfa One Nine Two – Alfa One Nine Two – WEAK BUT READABLE – OVER

Z34D, having nothing for A192, transmits:

Alfa One Nine Two – THIS IS - Zulu Three Four Delta – ROGER – OUT

Released 5 September 2001

UNCLASSIFIED

604. SEQUENCE OF CALL SIGNS AND/OR ADDRESS GROUPS

The following rules govern the sequence of call signs and/or address groups in calling and answering and of those included in components of messages.

- a. Call signs and/or address groups in message headings will ordinarily be arranged in alphabetical order in the form in which they are to be transmitted, whether plain or encrypted. For this purpose, / (slant) and figures 1 through 0 will be considered the twenty-seventh through thirty-seventh letters of the alphabet. Care must be exercised to avoid separating groups of related call signs and/or conjunctive address groups that are interdependent.
- b. When abbreviated call signs are used on a net, the sequence of answering a collective call is to be the same as if full call signs were in use. This avoids any confusion that may arise when changing from full to abbreviated call signs.
- c. If several stations are called in one transmission and one fails to answer in its turn, the next in turn answers after a 5-second pause. The defaulting station then answers last, if able to do so.

605. ESTABLISHING A NET

The use of procedure as prescribed herein shall be followed either when opening a net for the first time or when reopening a net. Proper control by the net control station (NCS) and adherence to operating rules by all stations within the net enable the net to begin and maintain an exchange of traffic with minimum delay. The NCS is also responsible for maintaining security on its net. Appropriate security guidance will be furnished by the NCS to all stations prior to establishing a net.

Example A:

At a designated time or when ready to establish the net, Z34D transmits:

Yankee One Three Charlie – THIS IS – Zulu Three Four Delta – OVER

Each subordinate station then answers the call in alphanumeric order:

THIS IS - Alfa One Nine Two – OVER

THIS IS - Charlie Two Zero Six – OVER

Released 5 September 2001

THIS IS - Delta Three Eight One – OVER

THIS IS - Echo Nine Six Nine – OVER

THIS IS - Foxtrot One Seven Eight – OVER

THIS IS - Hotel Seven Nine Five – OVER

The NCS now calls the net to inform all stations that their transmissions have been heard and that he has no traffic for them

THIS IS - Zulu Three Four Delta – OUT

Example B:

In this example, the subordinate station E969 is unable to answer the collective call. Z34D transmits:

Yankee One Three Charlie – THIS IS Zulu Three Four Delta – OVER

The first three stations then answer;

THIS IS - Alfa One Nine Two – OVER

THIS IS – Charlie Two Zero Six – OVER

THIS IS – Delta Three Eight One – OVER

F178, hearing no answer from E969, waits approximately 5 seconds and then transmits:

THIS IS – Foxtrot One Seven Eight – OVER

H795 follows on:

THIS IS – Hotel Seven Nine Five – OVER

After receiving answers from all stations except E969, Z34D transmits:

THIS IS Zulu Three Four Delta – ROGER – Echo Nine Six Nine –
NOTHING HEARD – OUT

Released 5 September 2001

UNCLASSIFIED

6-4

E9969, when able to transmit, calls the NCS to report into the net:

Zulu Three Four Delta – THIS IS – Echo Nine Six Nine – Reporting into net – OVER

Z34D transmits:

Echo Nine Six Nine – THIS IS – Zulu Three Four Delta – AUTHENTICATE..... - OVER

E969 transmits:

THIS IS – Echo Nine Six Nine – I AUTHENTICATE..... - OVER

Z34D transmits:

THIS IS – Zulu Three Four Delta – ROGER – OUT

606. ESTABLISHING COMMUNICATIONS

- a. Once the net has been established, it will normally work using abbreviated procedures and call signs as follows. The NCS may, however, order the net to revert to full procedures and call signs as dictated by the prevailing conditions.
 - (1) The proword THIS IS will normally be omitted from all calls
 - (2) Callsigns will be abbreviated IAW ACP 135
 - (3) Initial calls are optional IAW Para 613.
- b. Full Procedure. With full procedure, the use of prowords and call signs that were previously optional becomes mandatory.
 - (1) If, when establishing the net, the NCS judges that conditions are such that the use of abbreviated procedure will cause unnecessary repetitions, the NCS orders the use of full procedure.

Example:

Once the net has been established, the NCS transmits:

Yankee One Three Charlie – THIS IS – Zulu Three Four Delta – USE FULL PROCEDURE – OUT

- (2) If the net is working using abbreviated procedure and conditions deteriorate to such a degree that excessive repetitions are required, the NCS will order the use of full procedure.

Example:

The NCS orders the use of full procedure (assuming full call signs are in use);

Yankee One Three Charlie – THIS IS – Zulu Three Four Delta – USE FULL PROCEDURE – OVER

Each station answers in turn using full procedure:

Zulu Three Four Delta – THIS IS – Alfa One Nine Two – ROGER – OUT

Zulu Three Four Delta – THIS IS – Charlie Two Zero Six – ROGER – OUT

(The other stations on the net acknowledge in turn).

- c. Reverting to Abbreviated Procedure. When conditions return to normal, the NCS is to order that the net return to abbreviated procedure.

Example:

The NCS orders the use of abbreviated procedure (assuming abbreviated call signs are in use):

Three Charlie – THIS IS – Four Delta – USE ABBREVIATED PROCEDURE – OVER

Each station answers in turn using abbreviated procedure

THIS IS – Nine Two – ROGER – OUT

THIS IS – Zero Six – ROGER – OUT

- d. Full Call Signs. On establishing a net or at any other time when conditions require it, the NCS may order the use of full call signs in the same manner as for full procedure by using the proword USE FULL CALL SIGNS.

Released 5 September 2001

UNCLASSIFIED

- e. Abbreviated Call Signs. When conditions have returned to normal, the NCS will order the net to revert to the use of abbreviated call signs in the same manner as for abbreviated procedure by using the proword USE ABBREVIATED CALL SIGNS. When ordered to use abbreviated call signs, the net must continue to use either full or abbreviated procedure, whichever is in force.

Example:

The NCS orders the use of abbreviated call signs when full procedure is in force:

Three Charlie – THIS IS – Four Delta – USE ABBREVIATED CALL SIGNS – OVER

Each station answers in turn using abbreviated call signs but continuing to use full procedure:

Four Delta – THIS IS – Nine Two – ROGER – OUT

Four Delta – THIS IS – Zero Six – ROGER – OUT

- f. Full Procedure and Full Call Signs:

- (1) Conditions may be such that the NCS considers the use of both full procedure and full call signs necessary for the efficiency of the net. In this case, it will direct the net as follows:

USE FULL CALL SIGNS AND FULL PROCEDURE – OVER

- (2) When conditions warrant it, the NCS may subsequently order the net to use abbreviated call signs as shown in the above example or may order the net to abbreviate completely using the prowords USE ABBREVIATED CALL SIGNS and ABBREVIATED PROCEDURE.

607. ESTABLISHING A NET (TUNING)

- a. Z34D wishes to establish a net on a new frequency. At the time arranged for establishing communication, Z34D listens on the frequency and, finding it clear, transmits:

Yankee One Three Charlie – Yankee One Three Charlie – THIS IS Zulu Three Four Delta – Zulu Three Four Delta – Am about to transmit a tuning

Released 5 September 2001

signal – Zulu Three Four Delta – Zulu Three Four Delta (for 20 seconds) – NET NOW (holds down press-to-talk switch for 10 seconds) – OUT

- b. After allowing time for stations to adjust their transmitters, Z34D will establish communication as in paragraph 605. If any stations are off frequency, they will be given further tuning as follows:

Delta Three Eight One – THIS IS Zulu Three Four Delta – You are five kilohertz low

- Zulu Three Four Delta (for 20 seconds) – NET NOW – (hold down press-to-talk switch for 10 seconds) – OUT

Z34D transmits:

Delta Three Eight One – THIS IS – Zulu Three Four Delta – OVER

D381 transmits:

THIS IS – Delta Three Eight One – OVER

Z34D transmits:

Yankee One Three Charlie – THIS IS – Zulu Three Four Delta – OUT

608. DIRECTING A SHIFT IN FREQUENCY

- a. As with all other activities that change the characteristics of a net, a shift in frequency should be disguised as much as possible in the interest of communications security. Signal instructions for the net should, wherever possible, provide agreed nicknames to be used for foreseeable changes in frequency. If these are available, the following procedure will be used:

Example

The NCS changes the net to a new frequency using the nickname BLUE

TABLE:

Three Charlie – THIS IS – Four Delta – BLUE TABLE – OVER

Each subordinate station answers in turn:

THIS IS - Nine Two – ROGER – OVER

Released 5 September 2001

UNCLASSIFIED

THIS IS – Zero Six – ROGER – OVER

The NCS transmits the order to change:

THIS IS – Four Delta – BLUE TABLE now – OUT

- b. If the change is not planned or if there is no agreed nickname, the change is to be directed using a frequency designator. In such cases, authentication must be used.

Example A:

The NCS directs the net to change to a new frequency using the designator B11, where a transmission authentication system is in use:

Three Charlie – THIS IS – Four Delta – Change to Frequency Bravo One One – TIME 1816 – AUTHENTICATION IS..... – OVER (the time of authentication may be given if considered necessary depending on instructions for the authentication system in use).

Having verified the authentication, the subordinate stations answer in turn:

THIS IS – Nine Two – ROGER – OUT

THIS IS – Zero Six – ROGER – OUT, etc.

Example B:

The NCS changes the net to a new frequency using the designator B11 where a transmission authentication system is not in use:

Three Charlie – THIS IS – Four Delta – Change to Frequency Bravo One One – OVER

The first station to reply seek authentication:

THIS IS – Nine Two – AUTHENTICATE (challenge components) – TIME One Eight One Six - OVER (The time of authentication may be given if considered necessary, depending on instructions for the authentication system in use.)

The NCS Authenticates:

THIS IS – Four Delta – I AUTHENTICATE..... – OVER

The first station acknowledges both the authentication and the order to change frequency:

THIS IS – Zero Six – ROGER – OUT

THIS IS – Eight One – ROGER – OUT, etc.

- c. When the shift has been executed, the NCS will decide whether it is necessary under the conditions to check that the net has been re-established on the new frequency. In the interests of communications security, this should only be done if the NCS considers that the net may not be fully working for some reason. If the NCS does decide to re-establish the net, it will be done as described in paragraph 605

609. DIRECTED AND FREE NETS

- a. The type of net and method of operation is determined from consideration of operational factors involved.
 - (1) Free Net – In this type of net, the net control station (NCS) authorises member stations to transmit traffic to other stations in the net without obtaining prior permission from the NCS. Free net operation does not relieve the control station of the responsibility for maintaining circuit discipline.
 - (2) Directed Net – In this type of net, stations obtain permission from the NCS prior to communicating with other stations in the net. Permission is not required for the transmission of FLASH messages, which shall be sent direct. Transmissions on a directed net may also be accomplished in accordance with predetermined schedules.
- b. A net is deemed to be a free net unless otherwise ordered. When it is required to change a free net to a directed net, or vice versa, one of the prowords THIS IS A FREE NET or THIS IS A DIRECTED NET shall be used by the NCS.
- c. Directed Nets:
 - (1) The following example illustrates the manner in which the NCS announces that the net is directed and requests the amount and precedence of traffic to be transmitted (assuming abbreviated call signs are in use).

Example:

Released 5 September 2001

UNCLASSIFIED

UNCLASSIFIED

ACP 125 (F)

Z34D transmits:

Three Charlie – THIS IS – Four Delta – THIS IS A DIRECTED NET – of what precedence and for whom are your messages – OVER

Each subordinate station then answers in the alphanumeric order of his full call sign, indicating traffic on hand:

THIS IS – Nine Two – One IMMEDIATE and one ROUTINE for you – OVER

THIS IS - Zero Six – No Traffic – OVER

THIS IS – Eight One – ROUTINE for Nine Two – OVER

THIS IS – Six Nine – PRIORITY for Nine Five – OVER

THIS IS – Seven Eight – No Traffic – OVER

THIS IS – Nine Five – No Traffic – OVER

Z34D then informs the stations that their transmissions have been heard and commences to clear traffic in order of precedence:

Three Charlie – THIS IS – Four Delta – ROGER – Nine Two – Send your IMMEDIATE – OVER

After A192 completes his IMMEDIATE to Z34D, the NCS orders the station with the next highest precedence message to transmit his message:

Six Nine – THIS IS – Four Delta – Send your PRIORITY – OUT

H795, hearing this authorisation, tells E969 to go ahead:

THIS IS – Nine Five – OVER

(Failure of H795 to answer immediately would necessitate E969 making a preliminary call to H795.)

Nine Five – THIS IS – Six Nine – PRIORITY – TIME, etc.

After H795 receipts for the message and transmits the proword OUT, the NCS continues to authorise stations to transmit their messages in order of precedence until his traffic list is cleared.

- (2) When the traffic list is cleared, stations having messages to transmit should call the NCS and request permission to transmit.

Example:

Released 5 September 2001

UNCLASSIFIED

H795, having one ROUTINE message for C206, transmits:

Four Delta – THIS IS – Nine Five – ROUTINE for Zero Six – OVER

Z34D transmits:

THIS IS Four Delta – send your message – OUT or, if higher precedence traffic is awaiting transmission, THIS IS Four Delta – WAIT – OUT

When circuit conditions permit, Z34D informs H795 that they may transmit their message:

Nine Five – THIS IS – Four Delta – Send your message – OUT

C206, hearing the authorisation, should then transmit:

THIS IS Zero Six – OVER

This is in order to avoid requiring H795 to make a preliminary call. H795 then proceeds with the transmission of their ROUTINE message.

610. DELEGATING AND ASSUMING NET CONTROL

- a. It may be necessary for net control to be delegated to a subordinate station when effective net control cannot be maintained by the NCS or when the NCS has to leave the net for any reason. In such cases, the proword ASSUME CONTROL is to be used.

Example:

The NCS is closing down for 30 minutes and decides that D381 is in the best position to assume net control. He transmits:

Three Charlie – THIS IS – Four Delta – Am closing down for three zero minutes – Eight One – ASSUME CONTROL – TIME One Eight Three Zero Zulu – AUTHENTICATION IS..... – OVER

The subordinate stations answer in turn:

THIS IS - Nine Two ROGER – OUT

THIS IS – Zero Six – ROGER – OUT

THIS IS – Eight One – WILCO – OUT

Released 5 September 2001

UNCLASSIFIED

THIS IS – Six Nine – ROGER – OUT

THIS IS – Seven Eight – ROGER – OUT

THIS IS – Nine Five – ROGER – OUT

- b. Other occasions may arise where the NCS is not in a position to give warning that he is leaving the net. In such cases, the senior subordinate station will normally assume net control but, before he does so, he must confirm that other stations on the net cannot hear the NCS

Example:

Nothing has been heard from the NCS. E969, as the senior subordinate station, transmits:

Three Charlie – THIS IS – Six Nine – Have you heard anything from Four Delta

There is no reply from the NCS, and the other stations transmit:

THIS IS – Nine Two – NOTHING HEARD – OVER

THIS IS – Zero Six – NOTHING HEARD – OVER

E969 then transmits:

THIS IS – Six Nine – NOTHING HEARD from Four Delta – I AM ASSUMING CONTROL – OVER

Subordinate station reply in order:

THIS IS – Nine Two – ROGER – OUT

THIS IS – Zero Six – ROGER – OUT, etc.

- c. When the NCS re-joins the net, he does so using the proword I AM ASSUMING CONTROL and must give authentication:

Example:

The NCS wishes to resume control of the net and transmits:

Three Charlie – THIS IS – Four Delta – I AM ASSUMING CONTROL –
TIME One Eight Three Zero Zulu – AUTHENTICATION IS..... –
OVER

The subordinate stations reply in order:

THIS IS – Nine Two – ROGER – OUT

THIS IS – Zero Six – ROGER – OUT, etc.

611. RADIO CHECKS, SIGNAL STRENGTH AND READABILITY

- a. A station is understood to have good signal strength and readability unless otherwise notified. Strength of signals and readability will not be exchanged unless one station cannot clearly hear another station.
- b. A station that wishes to inform another of his signal strength and readability will do so by means of a short and concise report of actual reception such as, WEAK BUT READABLE, LOUD BUT DISTORTED, WEAK WITH INTERFERENCE, etc. Reports such as “five by five,” “four by four,” etc., will not be used to indicate strength and quality of reception.
- c. The prowords listed below are for use when initiating and answering queries concerning signal strength and readability:

(1) General:

RADIO CHECK

What is my signal strength and readability; how do you hear me?

ROGER

I have received your last transmission satisfactorily. The omission of comment on signal strength and readability is understood to mean that reception is loud and clear. If reception is other than loud and clear, it must be described with the prowords for (2) and (3) below.

Released 5 September 2001

UNCLASSIFIED

UNCLASSIFIED

ACP 125 (F)

NOTHING HEARD To be used when no reply is received from a called station.

(2) Report of Signal Strength:

LOUD Your signal is very strong.

GOOD Your signal strength is good.

WEAK Your signal strength is weak.

VERY WEAK Your signal strength is very weak.

FADING At times your signal strength fades to such an extent that continuous reception cannot be relied upon.

(3) Report of Readability:

CLEAR The quality of your transmission is excellent.

READABLE The quality of your transmission is satisfactory.

UNREADABLE The quality of your transmission is so bad that I cannot read you.

DISTORTED Having trouble reading you due to interference.

WITH INTERFERENCE Having trouble reading you due to interference.

INTERMITTENT Having trouble reading you because your signal is intermittent.

d. Example (Assuming Abbreviated Call Signs Are in Use):

Z34D desires a radio check with Y13C and transmits:

Three Charlie – THIS IS – Four Delta – RADIO CHECK – OVER

All stations of the collective call hear Z34D loud and clear except C206 and D381. The replies of each station, in order, are:

Released 5 September 2001

THIS IS – Nine Two – ROGER – OVER

THIS IS – Zero Six – READABLE – OVER

THIS IS – Eight One – WEAK WITH INTERFERENCE – OVER

THIS IS – Six Nine – ROGER – OVER

THIS IS – Seven Eight – ROGER – OVER

THIS IS – Nine Five – ROGER – OVER

Z34D indicates his reception of each of the called stations was loud and clear except for C206, who was distorted, and D381, who was not heard, by replying:

THIS IS – Four Delta – ROGER – Zero Six DISTORTED – Eight One – NOTHING HEARD – OVER

In the event Z34D hear all stations loud and clear, the reply would have been:

THIS IS – Four Delta – ROGER –OUT

612. PRELIMINARY CALLS

When communication is difficult or when the calling station wishes to ascertain whether the station called is ready to receive a message, a preliminary call will be sent before transmitting a message.

Example A:

C206 wishes to transmit a message to E969 and desires to know if E969 is ready to accept it. C206 transmits:

Six Nine – THIS IS – Zero Six – MESSAGE – OVER

E969, ready to accept the message, transmits:

THIS IS – Six Nine – SEND YOUR MESSAGE – OVER

Released 5 September 2001

UNCLASSIFIED

6-16

C206 transmits:

THIS IS – Zero Six – ROUTINE, etc.

Example B:

D381 wishes to transmit a message to H795 and desires to know that H795 is ready to accept it. D381 transmits:

Nine Five – THIS IS – Eight One – PRIORITY – OVER

H795, not prepared to accept the traffic immediately transmits:

THIS IS – Nine Five – WAIT

After a short pause, H795 is ready and transmits:

THIS IS – Nine Five – SEND YOUR PRIORITY – OVER

Note: If H795's delay had been longer than a few seconds, H795 would have transmitted:

THIS IS – Nine Five – WAIT – OUT

When ready to accept the message, H795 would transmit:

Eight One – THIS IS – Nine Five – SEND YOUR PRIORITY – OVER

613. TRANSMITTING A MESSAGE

- a. Communications Good. When communication reception is satisfactory, message parts need to be transmitted only once and preliminary calls are optional.

Example A:

Z34D transmits:

Seven Eight – THIS IS Four Delta – PRIORITY – Convoy has arrived – TIME One Six Three Zero Zulu – OVER

F178, having received the transmission satisfactorily, transmits:

THIS IS – Seven Eight – ROGER – OUT

Example B:

F178, having missed the transmission, transmits:

THIS IS – Seven Eight – SAY AGAIN – OVER

Z34D transmits:

THIS IS – Four Delta – I SAY AGAIN – (Seven Eight – THIS IS Four Delta) – PRIORITY – Convoy has arrived – TIME One Six Three Zero Zulu – OVER

F178 transmits:

THIS IS – Seven Eight – SAY AGAIN ALL AFTER Convoy – OVER

Z34D transmits:

THIS IS – Four Delta – I SAY AGAIN ALL AFTER Convoy – Convoy has arrived – TIME One Six Three Zero Zulu – OVER

F178 transmits:

THIS IS – Seven Eight – ROGER – OUT

- b. Communications Difficult. When communication is difficult, call signs should be transmitted twice. Phrases, words, or groups may be transmitted twice and indicated by use of the proword WORDS TWICE. Reception may be verified by use of the proword READ BACK.

Example A:

E969 transmits:

Alfa One Nine Two – Alfa One Nine Two – THIS IS – Echo Nine Six Nine – Echo Nine Six Nine – PRIORITY PRIORITY – OVER

A192 transmits:

Echo Nine Six Nine – Echo Nine Six Nine – THIS IS Alfa One Nine Two – Alfa One Nine Two – SEND YOUR PRIORITY – OVER

Released 5 September 2001

UNCLASSIFIED

6-18

E969 transmits:

Alfa One Nine Two – Alfa One Nine Two – THIS IS – Echo Nine Six Nine – Echo Nine Six Nine – WORDS TWICE – WORDS TWICE – PRIORITY – PRIORITY – Convoy has arrived – Convoy has arrived – TIME One Six Three Zero Zulu – TIME One Six Three Zero Zulu – OVER

A192 transmits:

Echo Nine Six Nine – Echo Nine Six Nine – THIS IS Alfa One Nine Two – Alfa One Nine Two – SAY AGAIN – SAY AGAIN – WORD BEFORE has – WORD BEFORE has – OVER

E969 transmits:

Alfa One Nine Two – Alfa One Nine Two – THIS IS Echo Nine Six Nine – Echo Nine Six Nine – I SAY AGAIN – I SAY AGAIN – WORD BEFORE has – WORD BEFORE has – Convoy – Convoy – OVER

A192 transmits:

Echo Nine Six Nine – Echo Nine Six Nine – THIS IS – Alfa One Nine Two – Alfa One Nine Two – ROGER – ROGER – OUT

Example B:

The text consists of code groups.

E969 transmits:

Alfa One Nine Two – Alfa One Nine Two – THIS IS Echo Nine Six Nine – Echo Nine Six Nine – WORDS TWICE – WORDS TWICE – PRIORITY – PRIORITY – TIME One Two Zero Nine Zero Three Zulu – TIME One Two Zero Nine Zero Three Zulu – GROUPS EIGHT – GROUPS EIGHT – Alfa Mike Lima Quebec Delta – Alfa Mike Lima Quebec Delta – Romeo Oscar Charlie Zulu Yankee – Romeo Oscar Charlie Zulu Yankee, etc. – OVER

A192 transmits:

Echo Nine Six Nine – Echo Nine Six Nine – THIS IS Alfa One Nine Two
– Alfa One Nine Two – ROGER – ROGER – OUT

614. RELAY

- a. The proword RELAY used alone indicates that the station called is to relay the message to all addressees.

Example:

Z34D transmits:

Nine Two – THIS IS Four Delta – RELAY – PRIORITY – TIME One
One One Three Two Two Zulu – FROM Four Delta – TO Nine Five –
Proceed on mission assigned – OVER

A192 transmits:

THIS IS Nine Two - ROGER – OUT

A192 relays the message:

Nine Five – THIS IS Nine Two – PRIORITY – TIME One One One Three
Two Two Zulu – FROM Four Delta – TO Nine Five – Proceed on mission
assigned – OVER

H795 transmits:

THIS IS Nine Five – ROGER – OUT

- b. The proword RELAY TO followed by an address designator indicates that the station called is to relay the message to the stations indicated. When more than one station is called, the call sign of the station designated to perform the relay will precede the proword RELAY TO.

Example A:

Z34D transmits:

Nine Two – THIS IS – Four Delta – RELAY TO Nine Five – PRIORITY
– TIME One One One Three Two Two Zulu – Proceed on mission
assigned – OVER

Released 5 September 2001

UNCLASSIFIED

UNCLASSIFIED

ACP 125 (F)

A192 transmits:

THIS IS Nine Two – Roger – OUT

A192 relays the message:

Nine Five – THIS IS – Nine Two – FROM Four Delta – PRIORITY –
TIME One One One Three Two Two Zulu – Proceed on mission assigned
– OVER

H795 transmits:

THIS IS – Nine Five – ROGER – OUT

Example B:

C206 transmits:

Eight One – Seven Eight – THIS IS Zero Six – Eight One – RELAY TO
Bravo Four Two Zero – ROUTINE – TIME Two One Zero Eight One Four
Zulu – FROM Charlie Two Zero Six – TO Bravo Four Two Zero – INFO
Delta Three Eight One – Foxtrot One Seven Eight – BREAK – Text –
OVER

D381 transmits:

THIS IS Eight One – ROGER – OUT

F178 transmits:

THIS IS Seven Eight – ROGER – OUT

D381 relays the message to B420

Note: In this case, D381 has relayed the message to B420, who is an off-net station, using radiotelephone procedure. At times, it is necessary to relay a message originated on a radiotelephone circuit by some other means of communications. When such relay is necessary, it is the responsibility of the station relaying the message to use the proper format for the means of communications employed for relay.

- c. The proword RELAY THROUGH allows the NCS or another station to indicate a station that can relay a message.

Example:

Released 5 September 2001

UNCLASSIFIED

F178 attempts to transmit a message to E969 but cannot contact him. The NCS directs F178 to relay through A192 who he knows to be in contact with E969:

Seven Eight – THIS IS – Four Delta – RELAY THROUGH Nine Two – OUT

F178 transmits:

Nine Two – THIS IS – Seven Eight – RELAY TO Six Nine – Move now – OVER, etc.

- d. The proword THROUGH ME allows a third station who knows that he is in contact with the required station to indicate that he is able to relay the message:

Example:

In the previous example, if the NCS had known that he was in contact with E969 he could have transmitted:

Seven Eight – THIS IS – Four Delta – THROUGH ME – OVER

- e. In all cases, whether the originating station can or cannot hear the relaying station, the relaying station must inform the originating station (station from whom the message was received for relay) that he has not been able to relay the message.

Example:

C206 requests D381 to relay a message to B420. D381 accepts but is unable to relay. D381 informs C206 and transmits Zero Six THIS IS Eight One UNABLE TO RELAY YOUR MESSAGE (DTG OR TEXT) TO Two Zero. C206 replies, Eight One THIS IS Zero Six ROGER OUT upon being informed that the message has not been passed and acknowledging the responsibility for clearing the message rests with C206.

Zero Six – THIS IS – Eight One – NOTHING HEARD from Two Zero – OVER

C206 replies:

Released 5 September 2001

UNCLASSIFIED

THIS IS Zero Six – ROGER – OUT, or as appropriate.

615. REPETITIONS

- a. When words are missed or are doubtful, repetitions are to be requested by stations before receiving for the message. The proword SAY AGAIN, used alone or in conjunction with ALL BEFORE, ALL AFTER, FROM, TO, WORD BEFORE, WORD AFTER, will be used for this purpose. In complying with requests for repetitions, the transmitting station will identify that portion which is being repeated.

Example A:

Z34D calls the two stations for which he has traffic:

Zero Six – Eight One – THIS IS Four Delta MESSAGE – ROUTINE – TIME Zero Eight One Zero Five Two Zulu – FROM Four Delta – TO Zero Six – INFO Eight One _ BREAK – At One Eight Zero Zero Zulu – Proceed Hong Kong – To Arrive One Six May – Load One Thousand Troops – for return Ningpo – I SPELL – November India November Golf Papa Oscar – Ningpo – ACKNOWLEDGE – OVER

C206, having missed from “At” to “Proceed,” transmits:

THIS IS Zero Six – SAY AGAIN – FROM At TO Proceed – OVER

Z34D deals with the request for repetitions by C206 before the other station requests his repetitions:

THIS IS Four Delta – I SAY AGAIN – FROM At TO Proceed – At Eight Zero Zero Zulu Proceed – OVER

C206, having now received the message satisfactorily, transmits:

THIS IS Zero Six – ROGER – OUT

Having heard C206 give a receipt for the message, the next station asks for his repetitions. In this case, D381 missed from “At” to “Proceed” and the word after “Load.” As C206 had already asked for the phrase from “At” to “Proceed” and D381 heard it repeated. It is not now necessary for him to request that part to be repeated. D381 asks, therefore, for the word after “Load” to be repeated:

THIS IS Eight One – SAY AGAIN – WORD AFTER Load – OVER

Released 5 September 2001

Z34D repeats the word:

THIS IS Four Delta – I SAY AGAIN – WORD AFTER Load – One – Over

D381, having now received the message satisfactorily, transmits:

THIS IS Eight One – ROGER – OUT

Example B:

Alternatively, the second station in the sequence of answering, not having heard the transmitting station answer the request for repetition within 5 seconds, transmits:

THIS IS Eight One – SAY AGAIN – WORD AFTER Load – OVER

Z34D having received a response from all stations concerned, transmits:

THIS IS Four Delta – I SAY AGAIN – At TO Proceed – At One Eight Zero Zero Zulu – Proceed – WORD AFTER Load – One – OVER

C206 transmits:

THIS IS Zero Six – ROGER – OUT

D381 transmits:

THIS IS Eight One – ROGER – OUT

- b. In requesting repetitions of the heading of a message, a repetition may be requested of all that portion of the heading preceding or following a proword, or that portion of the heading between any two prowords. Requests for repetitions and replies thereto must include the nearest proword preceding and/or following the portion requested.

Example A:

E969 transmits:

Zero Six – Seven Eight – THIS IS Six Nine – PRIORITY – TIME One Eight One Six Two Five Zulu – FROM Six Nine – TO Zero Six – Seven

Released 5 September 2001

UNCLASSIFIED

6-24

UNCLASSIFIED

ACP 125 (F)

Eight – INFO Bravo Four Two Zero – BREAK – Proceed to rejoin convoy
– OVER

C206, having missed all before the address, transmits:

THIS IS Zero Six – SAY AGAIN – ALL BEFORE FROM – OVER

E969 replies to C206:

Zero Six – THIS IS Six Nine – I SAY AGAIN – ALL BEFORE FROM –
Zero Six – Seven Eight – THIS IS Six Nine – PRIORITY – TIME One
Eight One Six Two Five Zulu – OVER

C206 transmits:

THIS IS Zero Six – ROGER – OUT

F178, having received the message satisfactorily, transmits:

THIS IS Seven Eight – ROGER – OUT

Example B:

D381 transmits:

Nine Five – THIS IS Eight One – ROUTINE – TIME Two Four Zero
Nine One Two Zulu – FROM Eight One – TO Nine Five – INFO – Bravo
Four Two Zero – BREAK – Cancel my Two Three One Four Two Eight
Zulu – OVER

H795, having missed the portion between the date-time group and the
information addressees, transmits:

THIS IS Nine Five – SAY AGAIN – FROM TIME TO INFO – OVER

D381 transmits:

THIS IS Eight One – I SAY AGAIN – FROM TIME TO INFO – TIME
Two Four Zero Nine One Two Zulu – FROM Eight One – TO Nine Five –
INFO – OVER

H795 transmits:

THIS IS Nine Five – ROGER – OUT

Released 5 September 2001

UNCLASSIFIED

- c. When it is necessary to ask for repetitions after a message has been received, such requests and replies there to must identify the message being queried as well as the portion required. Where used, the date-time group or time group shall be used for such identification.

Example:

Eight One THIS IS Nine Five – SAY AGAIN your Two Four Zero Nine One Two Zulu – OVER

Nine Five THIS IS Eight One – I SAY AGAIN – Nine Five – THIS IS Eight One – ROUTINE – TIME Two Four Zero Nine One Two Zulu – FROM Eight One – TO Nine Five – INFO – Bravo Four Two Zero – BREAK – Cancel my Two Three One Four Two Eight Zulu – OVER

THIS IS Nine Five – ROGER – OUT

616. CHECKING THE GROUP COUNT

- a. When a message consisting of coded groups is being received and the number of groups actually received does not correspond with the group count of the message, the receiving station requests a check by transmitting the phrase “Interrogative GROUPS...,” stating the number of groups actually received.
- b. When queried, the transmitting station will check and, if the number of groups received is correct, will indicate this by use of the proword CORRECT. The receiving station must then alter the group count accordingly.
- c. In all messages where words and groups are counted and the count is 50 or less, the transmitting station, if it considers the receiving station to be incorrect after it has questioned the group count, repeats the group count followed by the initial letter of each group. This will enable the receiving station to determine which groups are missing and to request a repetition.

Example A (Group Count Correct – Less Than 50 Groups):

D381 transmits:

Nine Two – THIS IS Eight One – ROUTINE – TIME One Four Two Zero Three Eight Zulu – GROUPS One Two – Delta Golf India – Lima Oscar

Released 5 September 2001

UNCLASSIFIED

UNCLASSIFIED

ACP 125 (F)

Papa – Juliett Tango Xray – Romeo Oscar Tango – Foxtrot Mike Xray – Oscar Papa India – Tango Romeo Sierra – Mike Delta Golf – Delta November India – Sierra Tango Delta – Golf Bravo Xray – Oscar Mike Bravo – OVER

A192, having received only 11 groups, transmits:

THIS IS Nine Two Interrogative GROUPS One One – OVER

D381 checks his group count against his transmission copy, finds it correct, and transmits:

THIS IS Eight One – GROUPS One Two – Delta Lima Juliett Romeo Foxtrot Oscar Tango Mike Delta Sierra Golf Oscar – OVER

D192 can now see which group he has missed and transmits:

THIS IS Nine Two – SAY AGAIN Five – OVER

D381 transmits:

THIS IS Eight One – I SAY AGAIN Five – Foxtrot Mike Xray – OVER

D192 transmits:

THIS IS Nine Two ROGER – OUT

Example B (Group Count Incorrect):

C206 transmits:

Seven Eight – THIS IS Zero Six – ROUTINE – TIME Zero Four One Two Five Two Zulu – GROUPS Eight – Mike Tango November – Sierra Uniform Bravo – Echo Lima Yankee – Golf Bravo Zulu – Foxtrot Oscar Uniform – Delta Oscar Papa – Oscar Bravo Juliett – OVER

F178, noticing that the group count and the number of groups he has received are at variance, transmits:

THIS IS Seven Eight – Interrogative GROUPS Seven – OVER

C206 checks his group count against the transmission copy, discovers his error, and transmits:

THIS IS Zero Six – CORRECT – OVER

Released 5 September 2001

UNCLASSIFIED

F178 transmits:

THIS IS Seven Eight – ROGER – OUT

- d. In all messages with a group count exceeding 50 groups, if the receiving station is considered to be incorrect the transmitting station repeats the original group count and transmits the identity of the first, eleventh, and every subsequent tenth group followed by the letter of that group.

Example (Group Count Correct – More Than 50 Groups):

D381 transmits a message containing 65 groups to A192.

A192 queries the group count:

Eight One THIS IS Nine Two – Interrogative GROUPS Six Five – OVER

D381 checks and finds the group count correct as sent. He then transmits:

THIS IS Eight One – GROUPS Six Five – One Mike – One One Sierra –
Two One Papa – Three One Romeo – Four One India – Five One
November – Six One Golf – OVER

A192 then request a repetition of the 10 groups in which he has a
miscount:

THIS IS Nine Two – SAY AGAIN – One One TO Two Zero – OVER

D381 then transmits the requested groups.

617. CORRECTIONS

- a. When a transmitting operator makes an error, the proword CORRECTION will be transmitted followed by the last word, group, proword, or phrase correctly transmitted. Transmission then continues.

Example A:

Released 5 September 2001

UNCLASSIFIED

UNCLASSIFIED

ACP 125 (F)

F178 transmits:

Nine Five – THIS IS Seven Eight – Convoy Romeo Three –
CORRECTION – Romeo Four should arrive – One Six Three Zero Lima –
TIME One Zero One Two Zulu – OVER

H795 transmits:

THIS IS Nine Five – ROGER – OUT

Example B:

C206 transmits:

Four Delta – THIS IS Zero Six – TIME Two Four Zero Seven One Two
Zulu – GROUPS Nine – Zulu Bravo Alfa Xray – Xray Oscar –
CORRECTION – Zulu Bravo Alfa Xray – Xray Quebec Alfa – Kilo, etc.

Z34D transmits:

THIS IS Four Delta – ROGER – OUT

Example C:

C206 transmits:

Seven Eight – THIS IS Zero Six – ROUTINE – TIME One Four Zero Six
Four Two Zulu – FROM Zero Six – TO Four Eight – CORRECTION –
TO Seven Eight – INFO Bravo Four Two Zero – Join Me – OVER

F178 transmits:

THIS IS Seven Eight – ROGER – OUT

Example D:

D381 transmits:

Zero Six – THIS IS Eight One – PRIORITY – TIME Zero Three One
Eight One Four Zulu – Latitude One Six Three Zero – Longitude One
Zero One Five – CORRECTION – Longitude One Zero Five Five –
OVER

C206 transmits:

Released 5 September 2001

UNCLASSIFIED

THIS IS Zero Six – ROGER – OUT

- b. When an error in transmission is made but not discovered immediately, a correction may be made in the final instructions element provided that the ending sign has not been transmitted. When making such a correction, the word, group proword, or phrase must be properly identified.

Example:

Nine Five - THIS IS Eight One - Tanks Will Arrive - Grid Three Two One
Nine Five Three - at Hotel Hours Minus Six - time One Four Two Six
Zulu - CORRECTION - WORD AFTER Minus - Five - OVER

D95 transmits:

THIS IS Nine Five – ROGER – OUT

- c. If it is necessary to make corrections after a receipt has been obtained for a message, an abbreviated service message, identifying the message and the portion to be corrected, should be made:

Example:

F178 transmits:

Nine Five – THIS IS Seven Eight – CORRECTION – My One Three One Five One Six
Zulu – WORD AFTER Monday – Morning – OVER

Released 5 September 2001

UNCLASSIFIED

6-30

618. CANCELLING MESSAGES

- a. During the transmission of a message and up to the transmission of the ending proword OVER or OUT, the message may be cancelled by use of the proword DISREGARD THIS TRANSMISSION – OUT.

Example:

During the transmission of a message E969 realises that the transmission is being sent in error and therefore cancels it:

Seven Eight – THIS IS – Six Nine – ROUTINE – TIME One Zero Zero Six Zero Two Zulu – Begin unloading at One One One Two Three Zero Zulu – Proceed – DISREGARD THIS TRANSMISSION – OUT

- b. A message that has been completely transmitted can only be cancelled by another message.

Example:

E969 transmits:

Seven Eight – THIS IS – Six Nine – Cancel my One Zero Zero Six Zero Two Zulu – TIME Zero Seven One Two Zulu – OVER

619. DO NOT ANSWER TRANSMISSIONS

When it is imperative that the called stations do not answer a transmission, the proword DO NOT ANSWER will be transmitted immediately following the call, and the complete transmission will be sent twice, the full transmission ending with the proword OUT. DO NOT ANSWER transmissions must be authenticated.

Example:

Sabine Raider transmits:

Siphon – THIS IS – Raider – DO NOT ANSWER – Act in accordance with Plan Charlie – TIME Two Two One Eight Zulu – AUTHENTICATION IS..... – I SAY AGAIN – Siphon – THIS IS Raider – DO NOT ANSWER – Act in accordance with Plan Charlie – TIME Two Two One Eight Zulu – AUTHENTICATION IS..... - OUT

620. READ BACK

- a. If it is desired that a message or portion thereof be read back to ensure accuracy, the proword READ BACK and identifying data; e.g., READ BACK TIME, READ BACK GRID, READ BACK TEXT, etc., will be transmitted immediately following the call:

Example A:

Z34D transmits:

Seven Eight – THIS IS – Four Delta – READ BACK – Convoy has arrived – Time One Six Three Zero Zulu – OVER

E178 transmits:

THIS IS Seven Eight – I READ BACK – Seven Eight – THIS IS Four Delta – READ BACK – Convoy has arrived – TIME One Six Three Zero Zulu – OVER

Z34D transmits:

THIS IS Four Delta – CORRECT – OUT

Example B:

C206 transmits:

Eight One – THIS IS Zero Six – READ BACK GRID – Meet Me Grid One Three Four Two Six Five – OVER

D381 transmits:

THIS IS Eight One – I READ BACK GRID – One Three Four Two Six Five – OVER

C206 transmits:

THIS IS Zero Six – CORRECT – OUT

Note: When READ BACK procedure is employed, the proword ROGER is not necessary to indicate receipt of the message.

Released 5 September 2001

UNCLASSIFIED

UNCLASSIFIED

ACP 125 (F)

- b. The proword READ BACK, when not preceded by identifying call signs, means that all stations are to read back. If a collective call is used, but only part of the stations represented in the call are required to read back, that station or those stations will be specified by transmitting the appropriate call signs preceding the proword READ BACK. When the order to read back is given, only those stations directed to do so will read back; remaining stations called will keep silent unless directed by the calling station to receipt.

Example:

Z34D transmits:

Three Charlie – THIS IS Four Delta – Eight One READ BACK – Convoy has arrived – TIME One Six Three Zero Zulu – OVER

D381 transmits:

THIS IS Eight One – I READ BACK – Three Charlie – THIS IS Four Delta – Eight One READ BACK – Convoy has arrived – TIME One Six Three Zero Zulu – OVER

C206 transmits:

THIS IS Zero Six – ROGER – OUT

- c. If the station reading back does so incorrectly, the originating station will call attention to the error by use of the proword WRONG followed by the correct version.

Example:

D381 read back:

THIS IS – Eight One – I READ BACK – Three Charlie – THIS IS – Four Delta – Eight One READ BACK – Convoy has arrived – TIME One Six Two Zero Zulu – OVER

Z34D transmits and directs C206 to receipt:

THIS IS Four Delta – CORRECT – Zero Six – OVER

C206 transmits:

THIS IS Zero Six – ROGER – OUT

Released 5 September 2001

UNCLASSIFIED

- d. If the station reading back does so incorrectly, the originating station will call attention to the error by use of the proword WRONG followed by the correct version:

Example:

D381 reads back:

THIS IS – Eight One – I READ BACK – Three Charlie – THIS IS – Four Delta – Eight One READ BACK – Convoy has arrived – TIME One Six Two Zero Zulu – OVER

Z34D transmits:

THIS IS – Four Delta – WRONG – TIME – One Six Three Zero Zulu – OVER

D381 transmits:

THIS IS – Eight One – TIME One Six Three Zero Zulu – OVER

Z34D transmits:

THIS IS – Four Delta – CORRECT – OUT

621. RECEIPT

- a. Receipt is employed in direct station-to-station traffic handling. No message is considered delivered until receipt is obtained (but see b below). A receipt may be effected as follows:
- (1) The receiving station transmits a receipt after each message or string of messages by the proword ROGER.
 - (2) Where abbreviated procedure is in force, a return transmission may be considered as a receipt if no confusion is likely to arise.
 - (3) In the case of a message requiring acknowledgment, the use of the proword WILCO constitutes a receipt (paragraph 622) as the meaning of WILCO includes that of ROGER.

Released 5 September 2001

UNCLASSIFIED

Example:

C206 transmits:

Six Nine – THIS IS – Zero Six – Send boat for mail – TIME One Seven
One Four Zulu – OVER

F969 transmits:

THIS IS – Six Nine – ROGER – OUT

- b. When the transmitting station considers speed of handling a primary consideration, one station in the net may be directed to receipt for the message and no other stations may answer until instructed to do so. This does not prohibit any station from requesting repetition. Security is enhanced if the same station is directed to receipt for all transmissions.

Example:

Station Z34D sends a message to the collective call Y13C and only desires a receipt from D381.

Z34D transmits:

Three Charlie – THIS IS Four Delta – Send boat for mail – TIME One
Two One Six Zulu – Eight One – OVER

D381 transmits:

THIS IS Eight One – ROGER – OUT

H795, having missed the word “mail,” transmits:

THIS IS Nine Five – SAY AGAIN – WORD AFTER for – OVER

Z34D transmits:

THIS IS Four Delta – I SAY AGAIN – WORD AFTER for – mail –
OVER

H795 transmits:

THIS IS Nine Five – ROGER – OUT

- c. Should either the transmitting or receiving station wish to indicate that he has further traffic to transmit to the station that he is working, this may be done by using the proword MORE TO FOLLOW in the message ending or receipt.

Example A:

C206, in transmitting a message to E969 wishes to indicate that he has further traffic for E969, transmits:

Six Nine THIS IS Zero Six – TEXT – MORE TO FOLLOW – OVER

THIS IS Six Nine – ROGER – OVER

Example B:

Z34D, in transmitting a message to Y13C wishes to indicate that he has further traffic for C206 and H795, transmits:

Three Charlie – THIS IS Four Delta – TEXT – MORE TO FOLLOW for Zero Six and Nine Five – OVER

THIS IS Nine Two – ROGER – OUT

THIS IS Zero Six – ROGER – OVER

THIS IS Eight One – ROGER – OUT

THIS IS Six Nine – ROGER OUT

THIS IS Seven Eight – ROGER OUT

THIS IS Nine Five – ROGER – OVER

THIS IS Four Delta, etc.

Example C:

E969, in receipting for a message from C206 wishes to indicate that he has a message for C206, transmits:

THIS IS Six Nine – ROGER – MORE TO FOLLOW – OVER

Released 5 September 2001

UNCLASSIFIED

6-36

UNCLASSIFIED

ACP 125 (F)

THIS IS Zero Six – OVER

Released 5 September 2001

UNCLASSIFIED

6-37

622. ACKNOWLEDGMENT OF MESSAGES

An acknowledgment should not be confused with a reply or receipt. A prompt reply referring to the message may serve in lieu of an acknowledgment. It is the prerogative of the originator to request an ACKNOWLEDGMENT to a message from any or all addressees of that message. If an acknowledgment is desired for a message, the request for acknowledgment normally is included in the text of that message. If the message has been transmitted, the request for acknowledgment will constitute a new message. Acknowledgments are originated only by the addressee to whom the request for acknowledgment was made. Procedure for acknowledgment of tactical signals is contained in paragraph 705.

Example:

Z34D transmits a message to D381 and desires an acknowledgment:

Eight One – THIS IS Four Delta – Search Area Delta –
ACKNOWLEDGE – TIME One One Two Zero Zulu – OVER

D381 transmits a receipt for the message:

THIS IS Eight One – ROGER – OUT

D381 operator, having shown the message to the commanding officer or his duly authorized representative and having been ordered to acknowledge the message, transmits:

Four Delta – THIS IS Eight One – Your One One Two Zero Zulu
Acknowledged – TIME One One Two Five Zulu – OVER

623. VERIFICATIONS

- a. When verification of a message or a portion thereof has been requested by an addressee, the originating station will verify with the originator and send the correct version.

Example:

H795 transmits:

Four Delta – THIS IS Nine Five – VERIFY Your One Zero Zero Eight
Zero One Zulu – ALL BEFORE BREAK – OVER

Released 5 September 2001

UNCLASSIFIED

Z34D transmits:

THIS IS – Four Delta – ROGER – OUT (or WAIT or WAIT OUT)

Z34D operator checks with the originator, establishes that the heading previously transmitted was correct, transmits:

Nine Five – THIS IS Four Delta – I VERIFY My One Zero Zero Eight Zero One Zulu – ALL BEFORE BREAK – Nine Five – THIS IS Four Delta – PRIORITY – TIME One Zero Zero Eight Zero One Zulu – FROM Four Delta TO Nine Five – INFO Zero Six – GROUPS One Seven – BREAK – OVER

H795 transmits:

THIS IS Nine Five – ROGER – OUT

- b. When a message to a number of addressees is queried by one station and found to be incorrect, the corrected version must be sent to all addressees.

Example:

D381 transmits:

Seven Eight – THIS IS Eight One – VERIFY Your Zero Eight Four Five Zulu – WORD AFTER Proceed – Haiphong – OVER

F178 transmits:

THIS IS Seven Eight – ROGER – OUT (or WAIT or WAIT OUT)

F178 operator checks the message with the originator and finds that the word after “proceed” should have been “Hong Kong” instead of “Haiphong.” He therefore transmits a correction to all the original addressees.

Eight One – Six Nine – THIS IS Seven Eight – CORRECTION – My Zero Eight Four Five Zulu – WORD AFTER Proceed – Hong Kong – OVER

D381 transmits:

THIS IS Six Nine – ROGER OUT

624. BREAK-IN PROCEDURE

- a. A station having a message of higher precedence than the transmission in progress may break in and thus suspend that transmission in the following circumstances:
 - (1) FLASH – Break in at once and transmit the message (b and c below).
 - (2) IMMEDIATE – May break in at once and pass the message. A preliminary call may be made before transmitting the message, if necessary. On a directed net, approval to transmit the message must be obtained.
 - (3) PRIORITY – As for IMMEDIATE except that only long ROUTINE messages should be interrupted.

Note: Break-in procedure will not normally be employed during the transmission of tactical messages except to report enemy contact.

- b. The precedence spoken three times means, “Cease transmissions immediately. Silence will be maintained until the station breaking in has passed the message.”
- c. Break-in procedure for messages of precedence FLASH on either a free net or a directed net should take the following form:

Example:

D381 is transmitting an IMMEDIATE message to Z34D when E969 is handed a FLASH message for transmission to A192. When D381 pauses, E969 transmits:

FLASH FLASH FLASH – Nine Two – THIS IS – Six Nine FLASH –
Text – OVER

A192 transmits:

THIS IS Nine Two – ROGER – OUT

D381 then continues with his transmission:

Released 5 September 2001

UNCLASSIFIED

UNCLASSIFIED

ACP 125 (F)

Four Delta – THIS IS – Eight One – ALL AFTER – etc.

- d. Break-in procedure for messages of IMMEDIATE or PRIORITY precedence is illustrated in the following examples:

(1) On Directed Nets:

Example:

D381 is transmitting a PRIORITY message to Z34D when E969 is handed an IMMEDIATE message for A192. When D381 pauses, E969 transmits:

IMMEDIATE IMMEDIATE IMMEDIATE – Four Delta – THIS IS – Six Nine – IMMEDIATE for Nine Two – OVER (D381, hearing E969's break-in, ceases transmission.)

NCS transmits:

THIS IS – Four Delta – Send your IMMEDIATE – OVER

On hearing this authorisation, A192 transmits:

Six Nine -THIS IS – Nine Two – OVER

E969 transmits:

Nine Two – THIS IS Six Nine – IMMEDIATE – Text – OVER

A192 transmits:

THIS IS – Nine Two ROGER – OUT

As soon as the IMMEDIATE message has been receipted, D381 continues his transmission:

Four Delta – THIS IS – Eight One – ALL AFTER – etc.

(2) On Free Nets:

Example A:

A192 is transmitting a PRIORITY message to D381 when Z34D is handed an IMMEDIATE message for E969. When A192 pauses, Z34D transmits:

IMMEDIATE IMMEDIATE IMMEDIATE –

Released 5 September 2001

UNCLASSIFIED

A192 hearing the precedence spoken three times, ceases transmission and Z34D continues:

Six Nine – THIS IS – Four Delta – IMMEDIATE – Text – OVER

E969 transmits:

THIS IS Six Nine – ROGER – OUT

A192 then continues transmission:

Eight One – THIS IS – Nine Two – ALL AFTER – etc.

Example B:

A192 is transmitting a long ROUTINE message to D381 when Z34D is hand a PRIORITY message for E969. When A192 pauses, Z34D transmits:

PRIORITY PRIORITY PRIORITY –

A192, hearing the precedence spoken three times, ceases transmission and Z34D continues:

Six Nine – THIS IS Four Delta – PRIORITY – Text – OVER

E969 transmits:

THIS IS – Six Nine - ROGER – OUT

A192 then continues his transmission:

Eight One – THIS IS – Nine Two – ALL AFTER – etc.

625. ELECTRONIC, RADIO AND EMERGENCY SILENCE

a. Electronic Silence:

- (1) Orders for the imposition of electronic silence will be issued in advance by secure means, and no executive order in connection

Released 5 September 2001

UNCLASSIFIED

with the imposition of electronic silence is to be passed in the clear, or by codeword, over radio.

- (2) The orders which impose electronic silence will also detail THE CIRCUMSTANCES IN WHICH, AND BY WHOM, IT MAY BE LIFTED OR BROKEN AS WELL AS THE PROCEDURE FOR LIFTING OR BREAKING. This will normally include the use of codewords and/or transmission authentication.
- (3) All stations must be on their guard against attempts by the enemy to induce a break of electronic silence by false messages. On no account is silence to be broken to request authentication of a station which transmits during electronic silence if that station has not given the proper codeword or self-authentication for lifting silence or an emergency break.

b. Radio Silence:

- (1) Radio silence may be imposed or lifted by the control station on the net, or nets, for which it is responsible.
- (2) Radio silence may be predetermined or may occur in an emergency. When predetermined, instructions for imposing, lifting, or breaking radio silence are to be passed by any secure means available. Emergency silence is described in sub para c. below.
- (3) Radio silence is to be imposed in accordance with the instructions given. This will normally be by the use of codewords, nicknames, or other predetermined designator. Lifting or breaking radio silence may be achieved in the same way, or by the use of transmission or self-authentication.

Example A, imposing radio silence by use of a nickname:

The NCS transmits to all subordinate stations:

Three Charlie – THIS IS – Four Delta – PAPER DOLL – OVER

Each subordinate station answers in turn:

THIS IS – Nine Two – ROGER – OVER

THIS IS – Zero Six – ROGER – OVER – etc.

The NCS transmits:

THIS IS – Four Delta – PAPER DOLL now – OUT

Note: This procedure cannot be distinguished from the procedure for closing down and changing frequency when using nicknames.

Example B, breaking radio silence by means of transmission authentication:

A192 has authority and reason, within the conditions ordered, to break radio silence. He transmits:

Four Delta – THIS IS – Nine Two – Sighting Report – TIME.....-
AUTHENTICATION IS..... – OVER

Z34D transmits:

THIS IS – Four Delta – ROGER – OUT

Note: The remainder of the net maintains radio silence; a break by one station does not lift silence.

Example C, lifting radio silence by means of transmission authentication:

The NCS transmits:

Three Charlie – THIS IS – Four Delta – SILENCE LIFTED –
TIME..... - AUTHENTICATION IS – OUT

c. Emergency Silence:

- (1) Emergency (radio) silence may be imposed or lifted only by competent authority.
- (2) When a transmission authentication system is in force, a station must always authenticate a transmission which imposes or lifts emergency silence, or which calls stations during periods of emergency silence.
- (3) Transmissions imposing emergency silence will be made twice through and ended with the proword OUT. Stations do not answer or receipt such transmissions.

Released 5 September 2001

UNCLASSIFIED

- (4) The proword SILENCE spoken three or more times means "Cease transmissions on this net immediately. Silence will be maintained until lifted"
- (5) After a call, use of the proword SILENCE spoken three or more times means "Stations addressed are to cease all transmissions on this net immediately."

Example:

To impose emergency silence on the net, the NCS transmits:

Three Charlie – THIS IS – Four Delta – SILENCE SILENCE SILENCE –
 TIME – AUTHENTICATION IS – I SAY AGAIN –
 Three Charlie – THIS IS – Four Delta – SILENCE SILENCE SILENCE –
 TIME – AUTHENTICATION IS OUT.

- (6) SILENCE spoken three or more times followed by a frequency or frequency designator means "Cease all transmissions immediately on frequency (or frequency indicated by the designator)."
- (7) SILENCE spoken three or more times followed by "all nets" means "Cease all transmissions immediately on all nets."

Example A:

To impose emergency silence on all stations on the frequency indicated by the designator C74, the NCS transmits:

Three Charlie – THIS IS – Four Delta – SILENCE SILENCE SILENCE –
 Charlie Seven Four – TIME - AUTHENTICATION IS –
 I SAY AGAIN – Three Charlie – THIS IS Four Delta – SILENCE
 SILENCE SILENCE – Charlie Seven Four – TIME –
 AUTHENTICATION ISOUT

Example B:

To impose emergency silence on all stations on 134.25MHz only, the NCS transmits:

Three Charlie – THIS IS Four Delta – SILENCE SILENCE SILENCE –
 One Three Four Decimal Two Five – TIME – AUTHENTICATION
 IS – I SAY AGAIN Three Charlie – THIS IS Four Delta –

SILENCE SILENCE SILENCE – One Three Four Decimal Two Five –
TIME – AUTHENTICATION IS OUT

Example C:

To impose emergency silence on all nets including subordinate nets, using the codeword BODYGUARD, the NCS transmits:

Three Charlie – THIS IS – Four Delta – SILENCE SILENCE SILENCE –
All nets – BODYGUARD – I SAY AGAIN - Three Charlie – THIS IS –
Four Delta – SILENCE SILENCE SILENCE – All nets – BODYGUARD
– OUT

Note: Subordinate NCS must repeat this message on their own nets using a different codeword or transmission authentication.

- (8) Emergency silence is lifted by the use of the proword SILENCE LIFTED, qualified where necessary by a frequency, a frequency designator, or the phrase “all nets” and followed by transmission authentication or a codeword, etc.

Example A:

Lifting emergency silence for all stations on a net, the NCS transmits:

Three Charlie – THIS IS – Four Delta – SILENCE LIFTED – TIME
..... - AUTHENTICATION IS – OUT

Example B:

Lifting emergency silence for all stations on a frequency indicated by the designator C74, using the codeword TOWER, the NCS transmits:

Three Charlie – THIS IS – Four Delta – SILENCE LIFTED – Charlie
Seven Four – TOWER – OUT

- d. Following a period of electronic or radio silence, the NCS needs to consider the requirement to re-establish communications by means of a radio check.

Released 5 September 2001

UNCLASSIFIED

626. CLOSING DOWN

- a. No station is to close down without prior permission from the NCS. The greatest care must be taken by control stations never to close down a net, or an individual subordinate station, without being completely satisfied that the stations know, or will know, the new frequency and time of reopening. The necessary orders are always passed by the most secure means and, wherever possible, not by radio.
- b. When it is essential to order a close-down over radio, and the NCS is satisfied regarding the arrangements for reopening, he orders the net or subordinate station to close down. He may do this by means of the proword CLOSE DOWN or by nickname.

Example A:

Z34D orders the close-down of the net using the nickname BLIND SPOT:

Three Charlie – THIS IS – Four Delta – BLIND SPOT – OVER

The subordinate stations reply in turn:

THIS IS – Nine Two – ROGER – OVER

THIS IS – Zero Six – ROGER – OVER, etc.

Z34D transmits:

THIS IS – Four Delta – BLIND SPOT now – OUT

Example B:

Z34D orders the close down of the net using the proword CLOSE DOWN:

Three Charlie – THIS IS – Four Delta – CLOSE DOWN – OVER

The subordinate stations reply in turn:

THIS IS Nine Two ROGER – OVER

THIS IS Zero Six – ROGER – OVER – etc.

Z34D transmits:

THIS IS Four Delta – CLOSE DOWN now – OUT

Released 5 September 2001

UNCLASSIFIED

6-48

CHAPTER 7**EXECUTIVE METHOD****701. GENERAL**

- a. The Executive Method is used when it is desired to execute a tactical message at a given instant; that is, to ensure that two or more units take action at the same moment.
- b. The operating rules in Chapter 6 apply equally to the Executive Method; however, it is the purpose of this chapter to amplify the basic procedure.
- c. Abbreviated plaindress format is normally used for messages transmitted by the Executive Method.
- d. When communications are good, it is not necessary to have all stations called acknowledge receipt of tactical messages. In these circumstances, only those stations whose call signs precede the proword OVER receipt for the message.
- e. The term "signal" used in this chapter refers to a type of message, the text of which consists of one or more letter, words, or signal flags, the prearranged meanings of which are found in tactical publications.
- f. Messages sent by Executive Method are never to have a time group included in the message ending.

702. EXECUTIVE METHODS

There are two Executive Methods:

- a. Delayed Executive Method.
- b. Immediate Executive Method.

703. DELAYED EXECUTIVE METHOD

A tactical message sent by the Delayed Executive Method will carry the warning proword EXECUTE TO FOLLOW in the message instruction, immediately preceding the text. The executive signal will be sent later in the form STANDBY – EXECUTE, the

Released 5 September 2001

latter word being the instant of execution. The text of the message being executed shall be repeated prior to transmission of the proword EXECUTE when:

- a. It is a portion of, or one of, several outstanding EXECUTE TO FOLLOW messages.
- b. A considerable time has elapsed between the transmission of an EXECUTE TO FOLLOW message and the transmission of the executive signal.

Example A:

Z34D transmits:

Three Charlie – THIS IS – Four Delta – EXECUTE TO FOLLOW – One Eight Five Corpen – OVER

All stations respond in alphabetical order of full call signs:

Nine Two – ROGER – OUT

Zero Six – ROGER – OUT

Eight One – ROGER – OUT

Six Nine – ROGER – OUT

Seven Eight – ROGER – OUT

Nine Five – ROGER – OUT

When ready to execute, Z34D transmits:

Three Charlie – THIS IS – Four Delta – Standby – EXECUTE – BREAK – Eight One – OVER

D381 transmits:

Eight One – ROGER – OUT

Example B:

Released 5 September 2001

UNCLASSIFIED

UNCLASSIFIED

ACP 125 (F)

To execute a portion of an outstanding Delayed Executive Method signal, Z34D transmits:

Three Charlie – THIS IS – Four Delta – EXECUTE TO FOLLOW – Formation One Two – Tack Speed Two Five – BREAK – Zero Six – Nine Five – OVER

C206 and H795 transmit:

Zero Six – ROGER – OUT

Nine Five – ROGER – OUT

When ready to execute Formation One Two, Z34D transmits:

Three Charlie – THIS IS – Four Delta – Formation One Two – Standby – EXECUTE – Nine Two, Seven Eight – OVER

A192 and F178 transmit:

Nine Two – ROGER – OUT

Seven Eight – ROGER – out

When ready to execute the remaining portion, Z34D transmits:

Three Charlie – THIS IS – Four Delta – Standby – EXECUTE – Zero Six – Nine Five – OVER

C206 and H795 transmit:

Zero Six – ROGER – OUT

Nine Five – ROGER – OUT

Example C:

To execute a Delayed Executive Method signal, Z34D transmits:

Three Charlie – THIS IS – Four Delta – EXECUTE TO FOLLOW – Formation One One – BREAK Eight One – Seven Eight – OVER

D381 and F178 transmit:

Eight One – ROGER – OUT

Released 5 September 2001

UNCLASSIFIED

Seven Eight – ROGER – OUT

Later, after a pause of several minutes, Z34D wishes to execute the signal and transmits:

Three Charlie – THIS IS – Four Delta – Formation One One – Standby – EXECUTE – Six Nine – Nine Five – OVER

E969 and H795 transmit:

Six Nine – ROGER – OUT

Nine Five – ROGER – OUT

704. IMMEDIATE EXECUTIVE METHOD

In cases of urgency, the executive signal may be transmitted in the final instructions element of the message to which it refers. To differentiate between this method and that laid down in paragraph 703, the transmission of the executive signal in the final instructions of the message to be executed is termed the “Immediate Executive Method.” It should be noted that:

- a. The use of the Immediate Executive Method does not allow stations to obtain verifications, repetitions, acknowledgments or cancellations before the message is executed.
- b. Messages made by the Immediate Executive Method should be in plain language, or should be limited to basic TURN, CORPEN, and SPEED signals.
- c. When using the Immediate Executive Method, the warning IMMEDIATE EXECUTE is used in the message instructions instead of the proword EXECUTE TO FOLLOW.
- d. The text of the signal is transmitted twice, separated by the proword I SAY AGAIN. The executive signal is transmitted in the final instructions.

Example:

Z34D transmits:

Released 5 September 2001

UNCLASSIFIED

UNCLASSIFIED

ACP 125 (F)

Three Charlie – THIS IS – Four Delta – IMMEDIATE EXECUTE –
BREAK – Turn Nine – Tack – Speed One Eight – I SAY AGAIN – Turn
Nine – Tack – Speed One Eight – Standby – EXECUTE – Zero Six –
Seven Eight – OVER

C206 and F178 transmit:

Zero Six – ROGER – OUT

Seven Eight – ROGER – OUT

705. ACKNOWLEDGEMENT OF SIGNALS

Signals, the purport of which required the accomplishment of a difficult manoeuvre, quite often require acknowledgment of not only the understanding of the signal but also the capabilities of the addressee to perform such a manoeuvre. In such cases, the originator adds the word “acknowledge” as the last word in the text. When the commanding officer or authorised representative is close to the operator, and no delay in answering will result, the proword WILCO will be used in receipting in lieu of the proword ROGER. However, when this situation does not exist, the operator shall receipt in the usual manner and send the proword WILCO later, when ordered.

Example:

Z34D transmits:

Nine Two – Nine Five – THIS IS – Four Delta – EXECUTE TO
FOLLOW – Uniform Golf Two – Tack One Five – Tack – Zero Zero Zero
– Tack – One Two – ACKNOWLEDGE – BREAK – OVER

The commanding officer of A192 is not in close proximity, or desires to consider the message before acknowledging.

A192 transmits:

THIS IS – Nine Two – ROGER – OUT

The commanding officer of H795 is in close proximity and directs his operator to acknowledge.

H795 transmits:

Released 5 September 2001

UNCLASSIFIED

THIS IS – Nine Five – WILCO – OUT

When ready to acknowledge, A192 transmits:

Four Delta – THIS IS – Nine Two – WILCO – (your last transmission) –
OUT

Or

Four Delta – Nine Five – THIS IS – Four Delta – Standby – EXECUTE –
Nine Two – OVER

A192 transmits:

THIS IS – Nine Two – ROGER – OUT

706. VERIFICATIONS AND REPETITIONS

Verifications and repetitions of tactical messages are made in accordance with paragraphs 615 and 623 except that verifications or repetitions of signals taken from a naval signal book must be for the entire transmission or for those portions separated by the “Tack.” (The word VERIFY may be used before receipt when the addressee is operating the circuit or is close to the operator.)

Example A, verification:

Three Charlie – THIS IS – Four Delta – EXECUTE TO FOLLOW – Zulu
Zulu One – Tack – Quebec Xray One – BREAK – Eight One – Nine Five
– OVER

D381 transmits:

THIS IS – Eight One – ROGER – OUT

H795 desires a verification of the first portion of the signal:

THIS IS Nine Five – VERIFY – FOLLOW TO – Tack – OVER

Z34D transmits:

Released 5 September 2001

UNCLASSIFIED

UNCLASSIFIED

ACP 125 (F)

THIS IS – Four Delta – ROGER – OUT or WAIT OUT

After verifying the signal with the originating officer, and finding the original version is correct, Z34D transmits:

Nine Five – THIS IS – Four Delta – I VERIFY – FOLLOW TO Tack – FOLLOW - Zulu Zulu One – Tack – OVER

H795 transmits:

THIS IS – Nine Five – ROGER – OUT

(This leaves the original signal with only “Quebec Xray One” awaiting execution.)

Z34D then transmits a new signal:

Three Charlie – THIS IS – Four Delta – EXECUTE TO FOLLOW – Zulu Zulu Seven – OVER

All stations receipt in the normal manner.

Z34D may now execute both outstanding EXECUTE TO FOLLOW signals with on EXECUTE:

Three Charlie – THIS IS – Four Delta – Standby – EXECUTE – Nine Five – OVER

H795 transmits:

THIS IS – Nine Five – ROGER – OUT

Example B, request for repetition:

Three Charlie – THIS IS – Four Delta – EXECUTE TO FOLLOW – Zulu Zulu One – Tack – Quebec Xray One – BREAK – Eight One – Nine Five – OVER

D381 transmits:

THIS IS – Eight One – ROGER – OUT

H795 desires a repetition of the signal:

Released 5 September 2001

UNCLASSIFIED

THIS IS Nine Five – SAY AGAIN – OVER

Z34D transmits:

THIS IS – Four Delta – I SAY AGAIN - Three Charlie – THIS IS – Four Delta – EXECUTE TO FOLLOW – Zulu Zulu One – Tack – Quebec Xray One – BREAK – Nine Five – OVER

THIS IS – Nine Five – ROGER – OUT

Example C, repetition of the call when unknown:

UNKNOWN STATION – THIS IS – Nine Five - SAY AGAIN – ALL BEFORE – EXECUTE TO FOLLOW – OVER

Nine Five – THIS IS Four Delta – I SAY AGAIN – Three Charlie – THIS IS – Four Delta – EXECUTE TO FOLLOW – OVER

THIS IS – Nine Five – ROGER – OUT

Example D, repetitions of the whole or any portion of the text:

Three Charlie - THIS IS – Four Delta – EXECUTE TO FOLLOW – Turn Starboard Nine Tack Tango Alfa One Two Tack One Tack Five – Nine Two – OVER

THIS IS – Nine Two – ROGER – OUT
Four Delta – THIS IS – Six Nine – SAY AGAIN – Starboard to Alfa – OVER

THIS IS – Four Delta – I SAY AGAIN – Starboard to Alfa – Starboard Nine Tack Tango Alfa – OVER

THIS IS – Six Nine – ROGER - OUT

707. EXECUTION OF NON-EXECUTIVE METHOD MESSAGES

Tactical messages taken from a signal book which do not employ Delayed Executive Method or Immediate Executive Method should have a time group included in the message ending. The use of a time group on a tactical message ordering action indicates that action is to be taken on receipt unless otherwise indicated in the text of the message.

Released 5 September 2001

UNCLASSIFIED

Example A (Action to be Taken on Receipt):

Z34D transmits:

Seven Eight – THIS IS – Four Delta – Station Bravo Three – TIME One
Six Four Two Zulu – OVER

F178 transmits:

THIS IS Seven Eight – ROGER – OUT

Example B (Action to be Taken at Time Indicated):

Z34D transmits:

Six Nine – THIS IS Four Delta – Yankee Mike Four – Tack – Tango One
Eight Answer – BREAK – TIME One Seven One Four Zulu – OVER

E969 transmits:

THIS IS Six Nine – ROGER – OUT

708. CANCELLING TACTICAL MESSAGES

- a. Tactical messages requiring cancellation shall be cancelled by the use of the proword NEGAT. Such messages can be cancelled individually or as a group.

Example A:

To cancel all signals transmitted to the same call and awaiting execution:

Three Charlie – THIS IS – Four Delta – NEGAT – TIME One Eight Three
One Zulu - OVER

Example B:

To cancel one of several signals awaiting execution:

Three Charlie – THIS IS – Four Delta – NEGAT – Turn Nine Tack –
Speed One Four – TIME One Eight One Five Zulu – OVER

Example C:

To cancel a portion of a signal awaiting execution:

Three Charlie – THIS IS – Four Delta – NEGAT – Speed One Four –
TIME One Eight One Five Zulu – OVER

- b. When a message is awaiting execution and a portion of it has been cancelled or executed, only the remainder of the message is considered to be outstanding.
- c. Messages sent by the Executive Method cannot be cancelled once the Executive signal EXECUTE has been transmitted.

Released 5 September 2001

UNCLASSIFIED

7-10

CHAPTER 8**MISCELLANEOUS PROCEDURES****801. METHOD OF SYNCHRONIZING TIME**

- a. If an accurate time check is desired, it will be requested by using the phrase "Request time check." The time at which the check is required may be indicated by the addition of a four-figure group. Time checks will be given in Greenwich mean time (GMT) unless otherwise requested or directed.

Example:

C206 requires to check his clock and transmits:

Four Delta – THIS IS Zero Six – Request time check – OVER

Z34D transmits:

THIS IS Four Delta – Time Check One Eight Zero Two Zulu (pause) One Five Seconds – One Zero Seconds – Five Four Three Two One – TIME One Eight Zero Two Zulu – OVER

C206 transmits:

THIS IS Zero Six – ROGER – OUT

- b. Should the occasion arise when the NCS desires to give an accurate time check to all stations on the net, he will pause a sufficient period of time between his warning phrase and the commencement of his countdown to allow all receiving operators to prepare their watches. The NCS may announce his intention of transmitting a time check at a certain time, using the phrase "Time Check at....."

Example:

Z34D transmits:

Three Charlie – THIS IS Four Delta Time Check at Zero Nine Three Zero Zulu (Pause to allow operators to prepare) – One Five Seconds – One Zero Seconds – Five Four Three Two One – TIME Zero Nine Three Zero Zulu – OVER

Released 5 September 2001

- c. Alternatively, a time check may be made by the Delayed Executive Method.

Example:

Z34D transmits:

Three Charlie – THIS IS Four Delta – EXECUTE TO FOLLOW – Tango
One Four One Five Zulu – BREAK – Six Nine – OVER

THIS IS Six Nine – ROGER – OUT

Z34D then transmits the executive signal to coincide with the time 1415:

Three Charlie – THIS IS Four Delta – Standby – EXECUTE – Nine Five –
OVER

THIS IS Nine Five – ROGER – OUT

802. GRID REFERENCES

- a. All grid references, including those encoded, are sent character by character, and all letters are to be pronounced phonetically. A grid reference in clear is easier to interpret if a pause is made between the two directional groups (i.e., between the 'east direction' and 'north direction' groups. Grid references are preceded by the proword GRID.

Example (In Clear):

Four Delta – THIS IS – Six Nine – Enemy at GRID – Three Two Six –
(pause) -Eight Four Seven – OVER

- b. When grid references are encoded in fixed low-grade codes, instructions relative to their use will apply.

803. BEADWINDOW PROCEDURE

- a. BEADWINDOW is a simple, rapid procedure for use by circuit operators to police the security of insecure voice networks. It brings to immediate attention of operators the fact that an Essential Element of Friendly Information (EEFI) has been disclosed on the circuit. Additionally, the

Released 5 September 2001

UNCLASSIFIED

UNCLASSIFIED

ACP 125 (F)

BEADWINDOW report serves to alert other operators on the net of the EEFI disclosure and thus acts as an educational aid, producing increased security awareness among operators and an overall improvement in the security of insecure voice communications.

- b. Use of BEADWINDOW in operations and exercises is mandatory. Its use is encouraged on all maritime insecure voice circuits as a minimum.
- c. The BEADWINDOW procedure uses a codeword (BEADWINDOW) and a number combination which transmitted immediately to the station disclosing an EEFI. When a station on the net transmits information listed in an EEFI, the net control operator (or any operator on the net in the event the net control operator fails to take action), transmits the codeword BEADWINDOW, followed by the number of the EEFI which has been disclosed.

Example: If an operator discloses a ship's position (disclosing EEFI number one from the list below), the net control operator will call the offending station and transmit:

BEADWINDOW ONE – OVER

The only authorised reply to a BEADWINDOW report is ROGER – OUT.

- d. Approved broad EEFIs for general use are listed below. An appropriate keyword or key phrase has been allocated to each EEFI for ease of training and rapid understanding of BEADWINDOW reports. Additional EEFIs for specific operations or exercises may be developed and broad EEFIs expanded by individual nations or by operational commanders and included in operations plans or orders. This may be accomplished by adding new EEFI categories (i.e., 8, 9, 10) or by expanding existing categories (e.g., 21-force composition, 22-force capabilities, 23-force limitation, etc.). The EEFI List should be posted in clear sight of the operator at all insecure voice positions for rapid reference.
- e. EEFI List:

Key Number and Key Word Definition:

- 1. (Position). Friendly or enemy position, movement or intended movement, position, course, speed, altitude, or destination of any air, sea, or ground element, unit or force.
- 2. (Capabilities). Friendly or enemy capabilities or limitations, force compositions, or identity; capabilities limitations, or significant casualties

Released 5 September 2001

UNCLASSIFIED

to special equipment, weapons systems, sensors, units or personnel.
Percentages of fuel or ammunition remaining.

3. (Operations). Friendly or enemy operations – intentions, progress, or results. Operational or logistic intentions – assault objectives – mission participants – flying programs – mission situation reports – results of friendly or enemy operations.
4. (Electronic Warfare). Friendly or enemy EW/EMCON – intentions, progress, or results, intention to employ ECM – results of friendly or enemy ECM – objectives of ECM – results of friendly or enemy ECCM – results of Electronic Warfare Support Measures (ESM) – present or intended EMCON policy – equipment affected by EMCON policy.
5. (Personnel). Friendly or enemy key personnel. Movement or identity of friendly or enemy flag officers, distinguished visitors, unit commanders – movement of key maintenance personnel indicating equipment limitations.
6. (COMSEC). Friendly or enemy COMSEC breaches – linkage of codes or codewords with plain language – compromise of changing frequencies or linkage with line numbers/circuit designators – linkage of changing call signs with previous call signs or units – compromise of encrypted/classified call signs – incorrect authentication procedure.
7. (Wrong Circuit). Inappropriate transmission. Information requested. Transmitted or about to be transmitted which should not be passed on subject circuit because it either requires greater security protection or is not appropriate to the purpose for which the circuit is provided.
8. (As required) For assignments as required
9. (As required) For assignments as required
10. (As required) For assignments as required

Released 5 September 2001

UNCLASSIFIED

CHAPTER 9**PROCEDURES FOR REPORTING ENEMY CONTACTS****901. INTRODUCTION**

Enemy contact reports shall be transmitted using basic radiotelephone procedure, as modified in this chapter. Details of enemy contact reporting are contained in Allied Maritime Tactical Instructions and procedures, ATP-1 (C), Volume 1, Chapter 10.

902. TRANSMISSION OF ENEMY REPORTS

- a. Enemy contact reports are normally to be made once only when in direct communication with officer in tactical command, higher authority, or shore radio station, except:
 - (1) When using DO NOT ANSWER procedure (paragraph 619).
 - (2) When the text consists of emergency alarm signals, in which case the text is made twice, separated by I SAY AGAIN, with a time group in the ending.
- b. When a ship that is stationed on a screen transmits an emergency alarm signal, the screen station may be indicated in the preamble before precedence.
- c. If desired by the originator, a READ BACK may be requested (paragraph 620).
- d. Authentication, when in force, should be used when making initial, amplifying, and negative reports in plain language or a brevity code. Lack of, or incorrect, authentication should not prevent re-transmission or relay of the message to higher authority.

Released 5 September 2001

903. EXAMPLES OF ENEMY CONTACT REPORTS

The WHEN component report of the contact may be transmitted either as the time group of the message or as the fourth component of the text. In the following examples, the former method is used with Abbreviated Plaindress Procedure (paragraph 502).

a. Initial Reports:

(1) Initial report in Standard Form as transmitted:

Four Delta – THIS IS Six Nine – FLASH – Locating One Serial One –
Four Delta Delta – Zero Nine Five Xray Xray One Four – Course Two
Seven Five – Speed Nine – Time Zero Nine Three Seven Zulu
AUTHENTICATION IS – OVER

THIS IS – Four Delta – ROGER – OUT

(2) Initial Report using emergency alarm signals, as transmitted:

Four Delta – THIS IS – Nine Five – Station Five – FLASH – Emergency
Quebec Zero Four Five Tack One Eight – I SAY AGAIN - Emergency
Quebec Zero Four Five Tack One Eight – TIME One Three Two Six Zulu
– AUTHENTICATION IS – OVER

THIS IS – Four Delta – ROGER – OUT

(3) Initial Report using ACP 165 Brevity Code, as transmitted:

Four Delta – THIS IS – Eight One – FLASH – Locating One Serial One –
Few Bogey (or Oscar Tango) – Two Four Six – Two Two – Closing –
TIME Two Three Zero One Zulu – AUTHENTICATION IS –
OVER

THIS IS – Four Delta – ROGER – OUT

(4) Initial Report in Abbreviated Form using READ BACK procedure,
as transmitted:

Four Delta – THIS IS Eight One – READ BACK – FLASH – Locating
Four Serial One – Three Juliett Juliett – Three Zero Zero Quebec Quebec
One Eight – TIME Zero Four Four Five Zulu – AUTHENTICATION IS
..... – OVER

Released 5 September 2001

UNCLASSIFIED

UNCLASSIFIED

ACP 125 (F)

THIS IS Eight One – CORRECT – OUT

(5) Initial Report using DO NOT ANSWER procedure, as transmitted:

Four Delta – THIS IS Nine Two – DO NOT ANSWER – FLASH –
Locating Two Serial One – Many Bogies – Two Five Five Tango Tango
Five – Closing – TIME One Nine Zero Zero Zulu – AUTHENTICATION
IS I SAY AGAIN - Four Delta – THIS IS Nine Two – DO NOT
ANSWER – FLASH – Locating Two Serial One – Many Bogies – Two
Five Five Tango Tango Five – Closing – TIME One Nine Zero Zero Zulu
– AUTHENTICATION IS – OUT

b. Amplifying Reports:

(1) First Amplifying Report using ACP 165 Brevity Code, as transmitted:

Four Delta – THIS IS Nine Two – IMMEDIATE – Locating One Serial
Two – Altitude Zero Nine Zero – Three Zero Five Cape Bon Two One –
TIME One Zero Four Zero Zulu – AUTHENTICATON IS –
OVER

THIS IS Four Delta – ROGER – OUT

(2) Amplifying Report using groups from the Allied Maritime Tactical
Signal Book, as transmitted:

Four Delta – THIS IS Nine Two – IMMEDIATE – My One Three Two
Five Zulu – Papa Xray One Eight – TIME One Three Three Zero Zulu –
AUTHENTICATION IS – OVER

THIS IS Four Delta – ROGER – OUT

(3) Amplifying Report using READ BACK procedures, as transmitted:

Serial Three THIS IS – Nine Five – READ BACK – IMMEDIATE –
Locating Four – Tracking Zero Five Eight – TIME Zero Four Five Zero
Zulu – AUTHENTICATION IS - OVER

THIS IS – Nine Five – CORRECT – OUT

(4) Amplifying Report using DO NOT ANSWER procedure, as transmitted.

Released 5 September 2001

UNCLASSIFIED

Four Delta – THIS IS – Zero Six – DO NOT ANSWER IMMEDIATE –
Locating Two Serial Three – Altitude One Zero Zero –
AUTHENTICATION IS I SAY AGAIN – Four Delta – THIS IS –
Zero Six – DO NOT ANSWER IMMEDIATE– Locating Two Serial
Three – Altitude One Zero Zero – AUTHENTICATION IS - OUT

c. Negative Report, as transmitted:

Four Delta – THIS IS Zero Six – IMMEDIATE – Negative Enemy – Zero
Two Seven Quebec Quebec One Eight – Tack – One Two – TIME One
Eight Four Six Zulu – AUTHENTICATION IS - OVER

THIS IS – Four Delta – ROGER - OUT

Released 5 September 2001

UNCLASSIFIED

